

**HOMOLOGERINGS  
DOKUMENT**  
**Dell'Orto PHBG 18BS**

Homologeringsnr.  
64/CR/09

Utgave 01/2012

<b>Produsent</b>	Dell'Orto S.p.A
<b>Merke</b>	Dell'Orto
<b>Modell</b>	PHBG 18 BS – Reg. 2523
<b>Homologeringsperiode</b>	1. januar 2006 – 31. desember 2009



**BILDE AV FORGASSER – FORFRA**



**BILDE AV FORGASSER - BAKFRA**

## MÅLSKISSE - FORGASSER

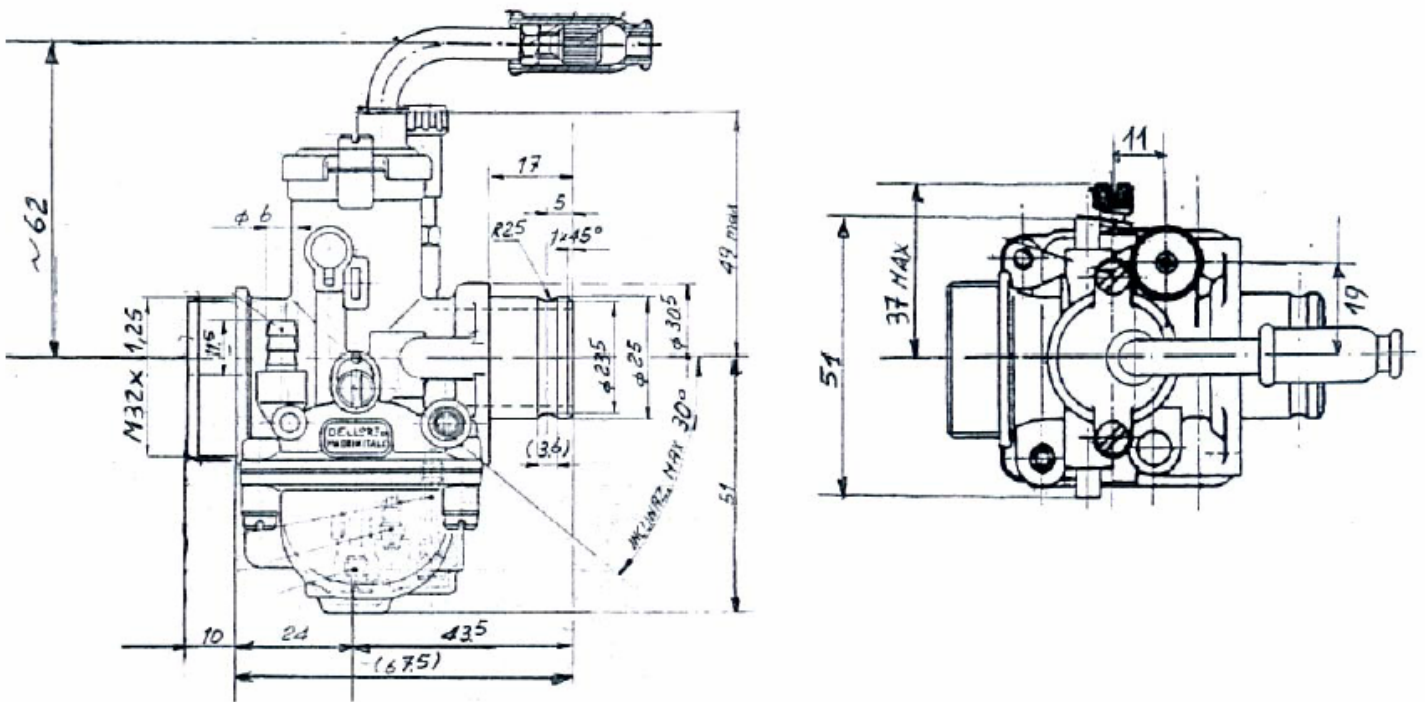

Forgasserhuset skal være orginalt og ubearbejdet.

Innmaten er fri, men det er kun lov å benytte Dellorto's originale ubearbejdede deler.

SPRENGSKISSE PHBG 18BS REG. 2523

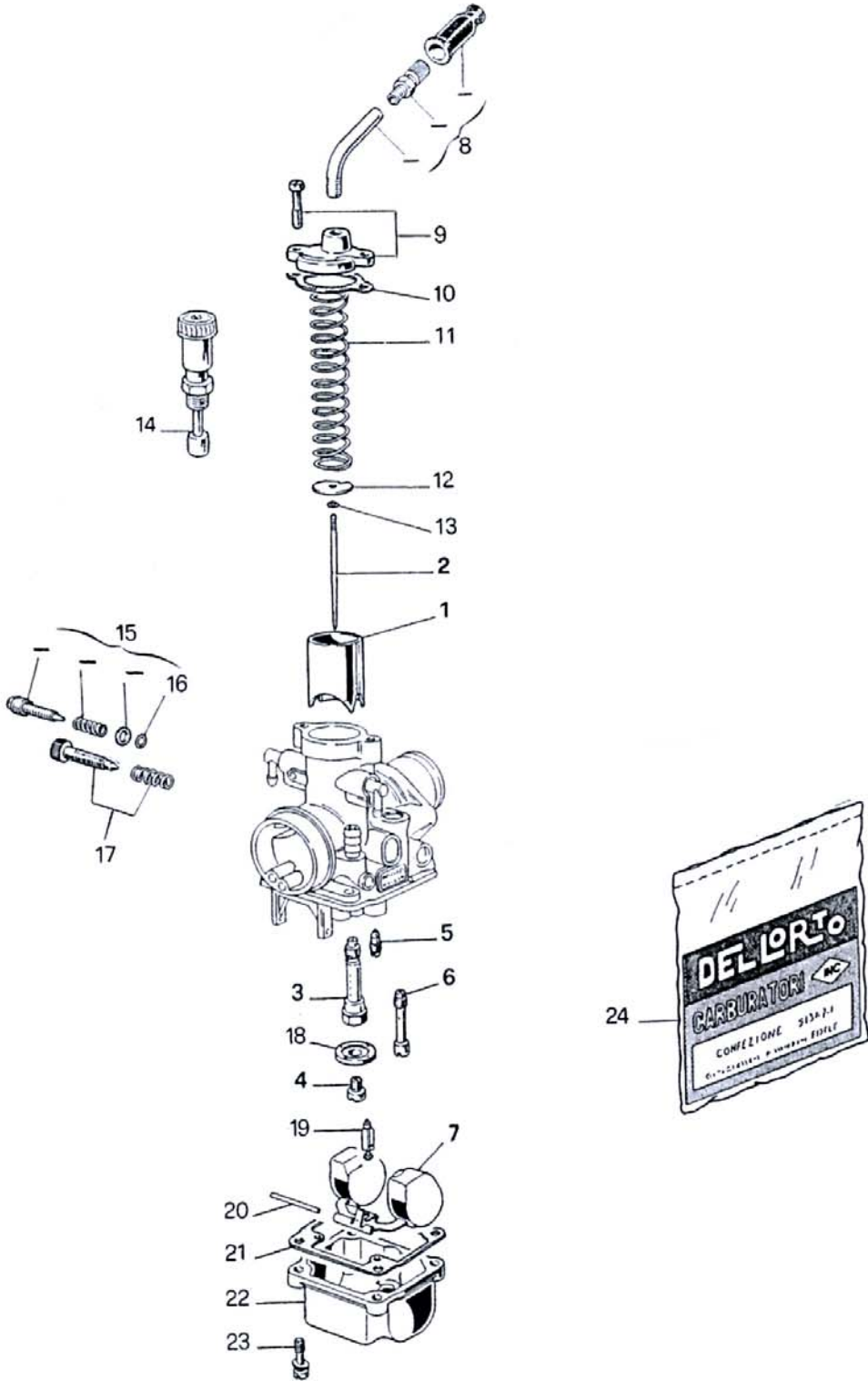

## DELELISTE PHBG 18BS REG. 2523

1	9475 x 64	THROTTLE VALVE
2	9595 x 08	NEEDLE
3	9511 x 28	ATOMISER
4	1486 x 02	MAIN JET
5	1488 x 02	IDLE JET
6	9501 x 02	STARTER JET
7	9450 x 80	FLOAT
8	53036 - 78	ELBOW 90° KIT
9	53031 - 78	VALVE CHAMBER COVER KIT
10	•	GASKET COVER
11	9597 - 61	SPRING VALVE
12	14958 - 21	PLATE
13	9596 - 21	CLIP
14	9538 - 64	MANUAL CHOKE
15	53024 - 78	IDLE MIXTURE ADJUSTING SCREW KIT
16	•	GASKET
17	53027 - 78	THROTTLE VALVE ADJUSTING SCREW KIT
18	9779 - 52	ANTI-SURGE WASHER
19	2838 - 05	FUEL VALVE
20	9506 - 22	PIN
21	•	GASKET
22	9444 - 96	FLOAT CHAMBER
23	11836 - 36	SCREW
24	52526 - 77	GASKET SET

• = enclosed in gasket set