



NORGES BILSPORTFORBUND

HOMOLOGERINGS DOKUMENT SONIK TX 125

Homologeringsnr.
NBF-09/M/14

Utgave 01/2010

Produsent	SONIK S.R.L	
Merke	SONIK	
Modell	TX 125	
Homologeringsperiode	1. Januar 2010 - 31. Desember 2014	8 Sider (+1)

Manufacturer Address
Sonik S.r.l.
Via Ragazzi del'99 7/A
42100 Reggio Emilia
Italy

Sonik Engine Specification Form

Engine
#

Manufacturer	SONIK S.R.L.
Make	SONIK
Model	TX 125
Inlet type	REED VALVE
Number of pages	8

PICTURE OF ENGINE



Importer: TS Racing, Inc. (352) 793-9600



TECHNICAL INFORMATION

A	CHARACTERISTICS	
	Measurement	Tolerances
Volume of cylinder	125 c.c.	MAX
Original Bore	54.02 mm	
Theoretical maximum bore	54.30 mm	
Stroke	54.00 mm	+/- 0.20 mm
Cooling system	WATER	
Number of carburation systems	1	
Number of transfer ports / ducts, cylinder/sump	3/3	
Number of exhaust ports / ducts	3	
Shape of the combustion chamber	SPHERICAL	
Length between the axes of the connecting rod	102 mm	+/- 0.10 mm
Weight of the connecting rod	125 g.	+/- 10 g.
Volume of combustion chamber	8 c.c.	MIN
Type of bearings	Crankshaft 6205, 52mm OD	

B	OPENING ANGLES	
Exhaust	179°	MAX
Of exhaust ports / ducts	128° / 135°	MAX

C	ACCESSORIES INCLUDED	
Carburettor with butterfly Ø24	Tryton M1	
Airbox	Two tubes	
Electric starter		
Battery		
Centrifugal clutch		
Exhaust with flex		

D	MATERIAL	
Cylinder	ALLUMINIUM ALLOY	
Connecting Rod	STEEL ALLOY	
Crankshaft	STEEL ALLOY	
Head	ALLUMINIUM ALLOY	
Liner	IRON ALLOY	
Crankcase	ALLUMINIUM ALLOY	
Piston	ALLUMINIUM ALLOY	
Piston Ring	IRON ALLOY	



DRAWING OF THE CYLINDER DEVELOPMENT

Chord reading

B = 52.5 mm C1=C2= 28.6 mm C3 = 28.7 mm (tolerances +/- 0.3mm)

Angular reading by inserting a 0.2mm gauge

E = 31.9 mm F = 42.5mm G = 41.8 mm (tolerances +/- 0.3mm)

(Insert drawing here)

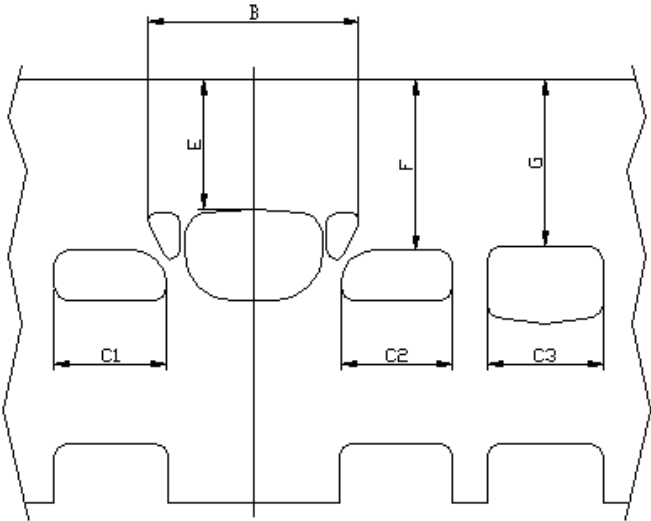

DRAWING OF THE CYLINDER BASE

(Insert drawing here)

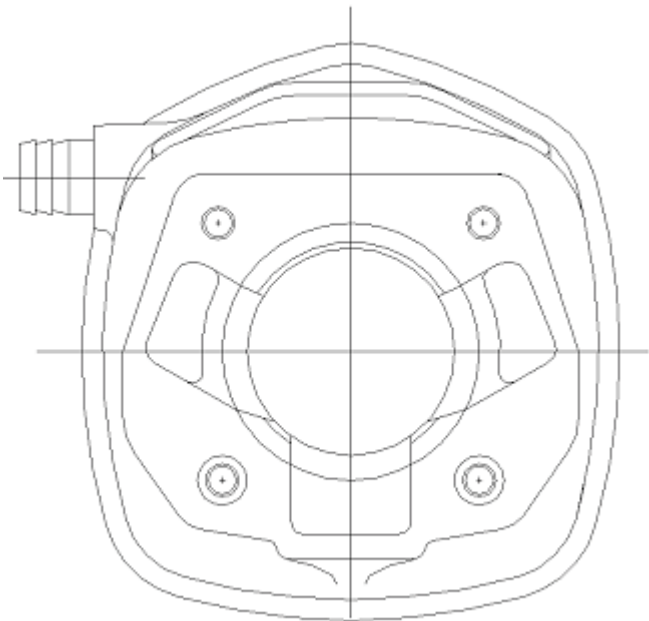

CYLINDER SECTION VIEW

(Insert drawing here)

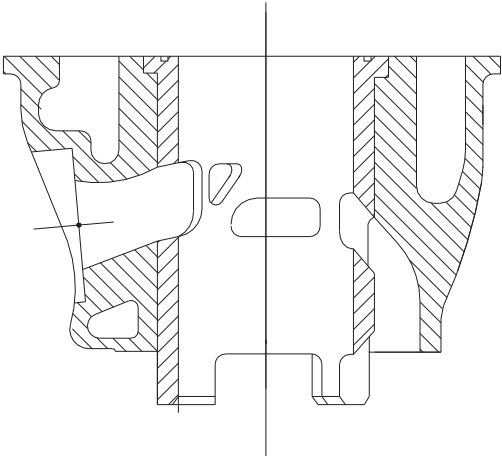



DRAWING OF THE CYLINDER HEAD AND THE COMBUSTION CHAMBER

(Insert drawing here)

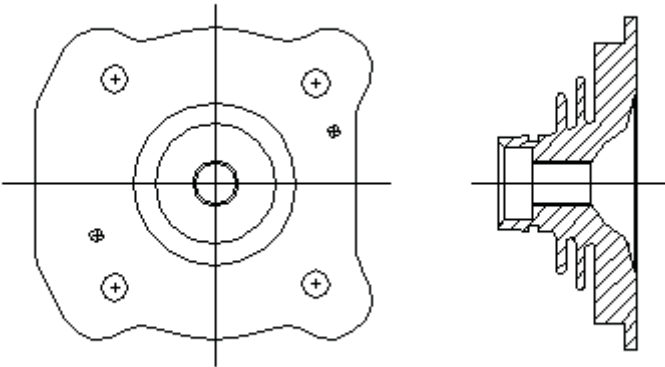

Combustion chamber volume = **8 c.c.** minimum (without thread)

DRAWING OF THE CRANKSHAFT

Complete weight = **2007 g. ± 20 g.**
(tolerances +/-0.10 mm)

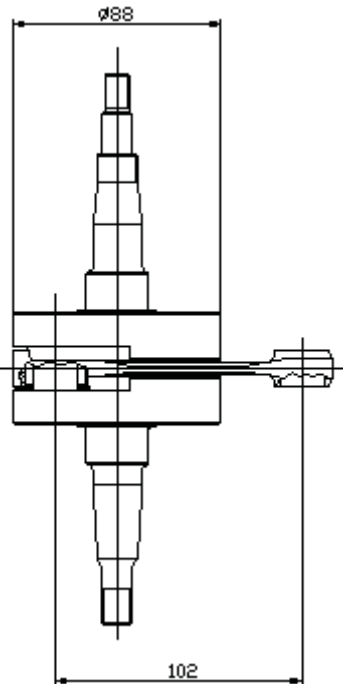

DRAWING OF THE INSIDE OF SUMP

(tolerances +/-0.10 mm)

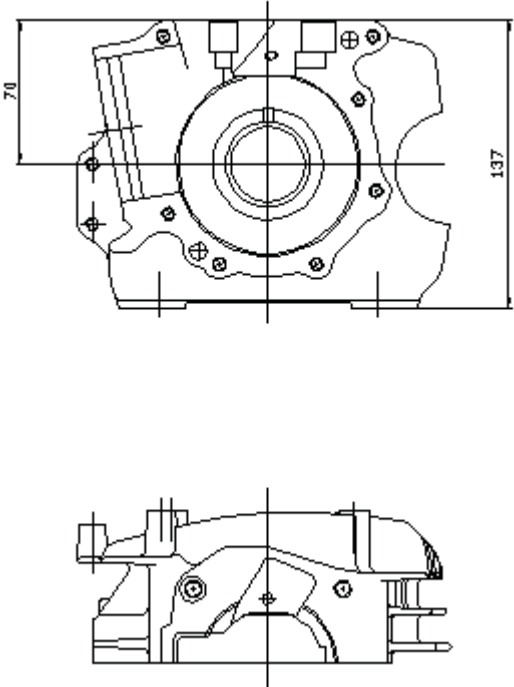



IGNITION	
Manufacturer	Selettra
Model Number	P3356E
Rotation	Counter-clockwise
Description	Sonik - Red

PHOTO OF IGNITION

(insert photo of inside here)



PHOTO OF COIL

(Insert photo here)

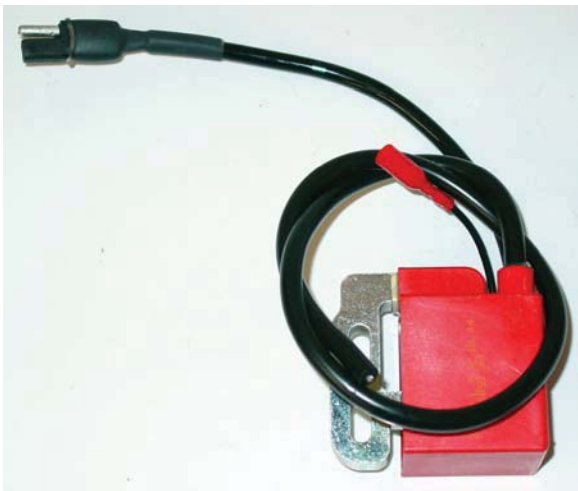

(insert photo of outside here)



Ignition Timing:
.070" to .085" BTDC
1.77mm to 2.16mm BTDC



CARBURETTOR DIMENSION

(Insert drawing here)

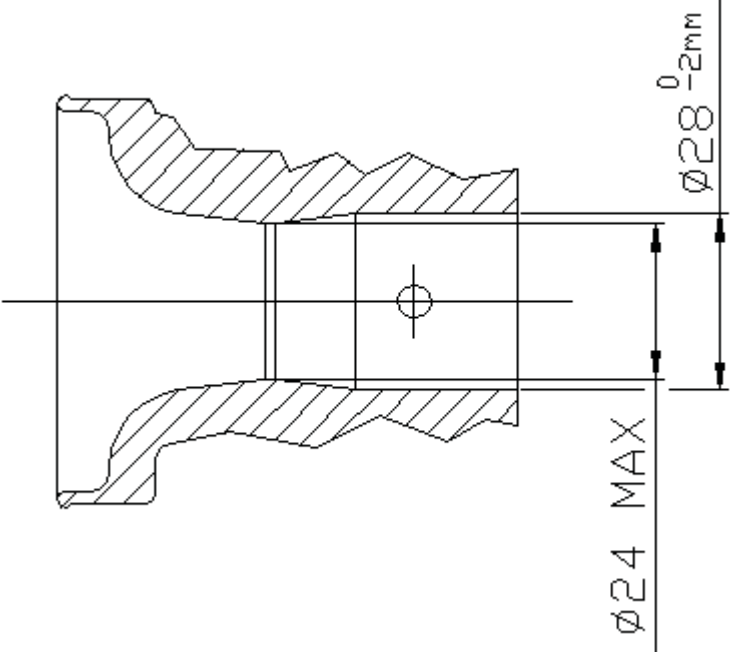

PISTON

Weight= **134 g \pm 7 g**
(Insert drawing here)

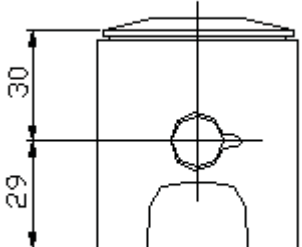

DISTANCE BETWEEN CONROD CENTERS

Weight= **125 g \pm 10 g**
(Insert drawing here)

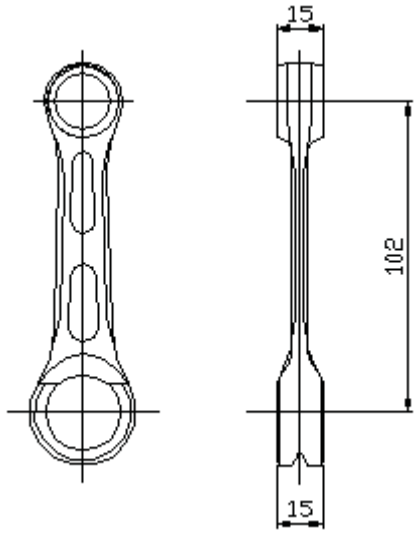

DESSIN DU SILENCIEUX ET DE SES
ÉLÉMENTSDRAWING OF THE SILENCER AND OF ITS
COMPONENTS

Épaisseur minimum de la paroi du pot-silencieux 0,8mm / Minimum thickness of the wall of the exhaust silencer 0.8mm.
Poids minimum de l'échappement _ 1,5 Kg / Minimum weight of the exhaust _ 1,5 Kg.

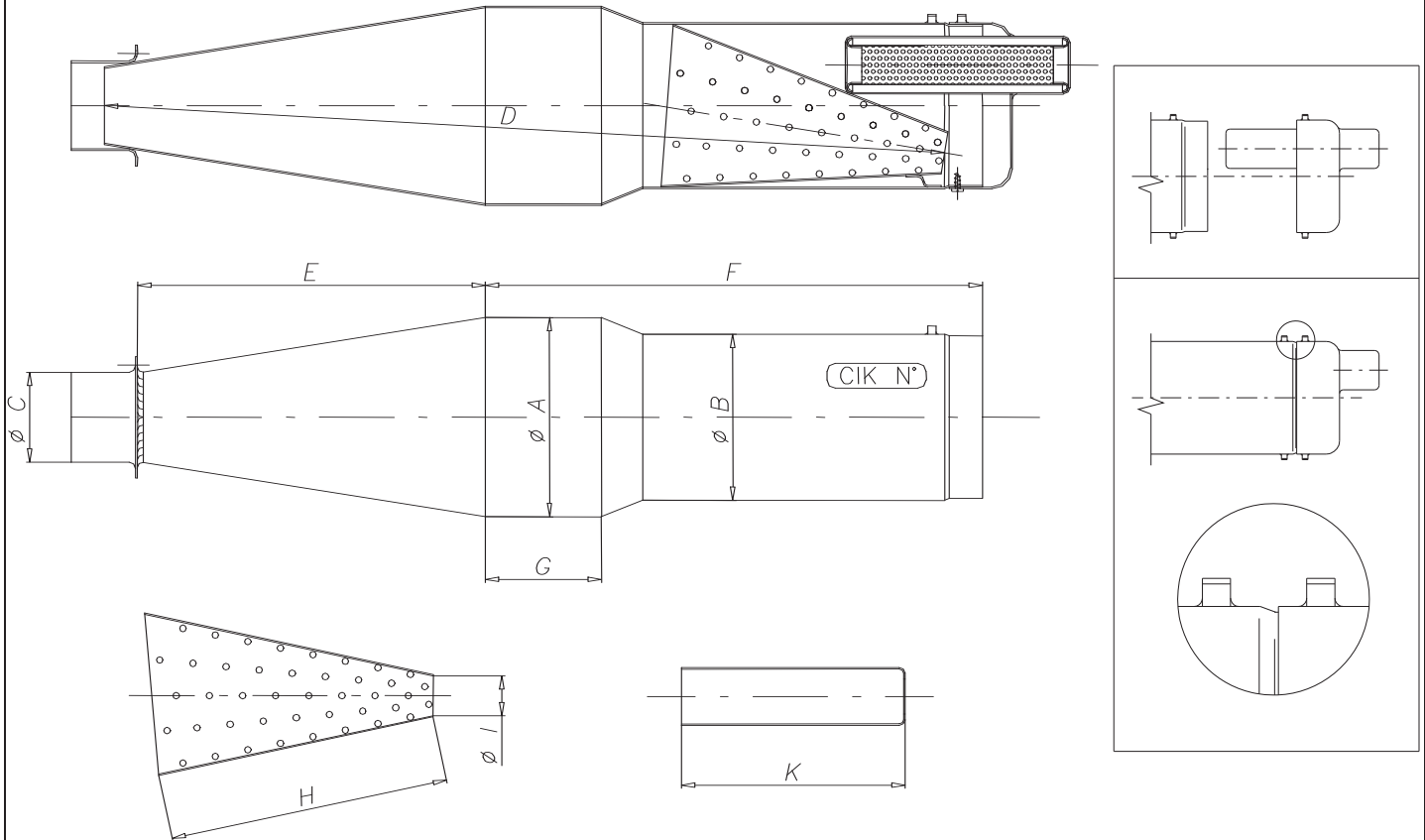

Les parties terminales du silencieux doivent présenter deux paires d'anneaux soudés (une en haut et une en bas), pour retenir le sceau en plomb fixé par l'Organisateur pour que le silencieux ne puisse pas être ouvert pendant la compétition.

The end parts of the silencer must have two soldered pairs of lugs (one pair at the top and one pair at the bottom) for the fixing of seals by the Organiser so that the silencer may be opened during the competition

Cotes / Readings:

A: _107.5_ Øext.

F: _318

B: _100_ Øext.

G: _100

C: _54_ Øext.

H: _170

D: _479

I: _21

E: _178.5

K: _130

TOLÉRANCES

Cotes brutes / Rough dimensions
Jusque - up to 25mm → ±1mm
De à - from to 25-60 → ±1,5mm
Plus que - more than 60mm → ±3mm



DRAWING OF THE SILENCER

(Insert drawing here)

See above drawing

DRAWING OF THE CLUTCH

Sonik Disc Clutch

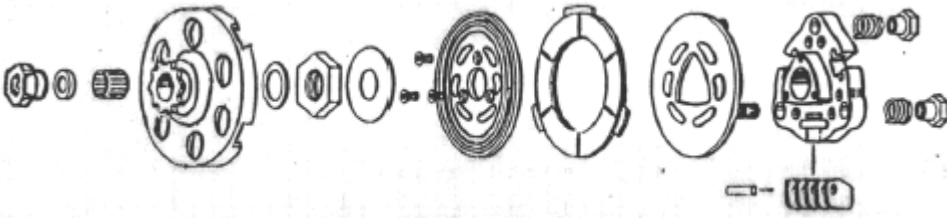

Sonik Shoe Clutch

