



# Automobile Club d'Italia

COMMISSIONE SPORTIVA AUTOMOBILISTICA ITALIANA

**SCHEDA  
EVOLUZIONE DEL TIPO  
MOTORE 60cc  
MINIKART & BABYKART**

Form. ET 60cc

N. OMOL.  
**06/MT/14  
01/ET/14**

Costruttore	LENZOKART SRL
Marca	LKE
Modello	R12
Validità Omologazione	2010 – 2014

Pagine 4

## DESCRIZIONE DELLA EVOLUZIONE

1. Inserimento ulteriori quote rispetto a quelle in scheda  
~~ÁÁÁ~~ *Insertion of further dimensions vs the ones shown on the form* ~~Á~~
2. Inserimento di 3 foto del pistone come da FAC-SIMILE ~~ÁÁ~~  
~~ÁÁÁ~~ *Insertion of 3 pictures of the piston as per FAC-SIMILE* ~~Á~~
3. Disegno tecnico e quote COLLETTORE di SCARICO ~~ÁÁÁ~~  
~~ÁÁÁ~~ *Exhaust manifold technical drawing and dimensions* ~~Á~~
4. Disegno tecnico e quote di 1 FLANGIA come OPTIONAL  
*Technical drawing and dimensions of the flange (OPTIONAL)*

Data li, 30/11/2010

Firma e Timbro dell'ASN

Firma e Timbro del Costruttore



DISEGNO E QUOTE PISTONE/I

Opzione 1

Opzione 2



FOTO DEI PISTONI Lato Spinotto

Opzione 1

Opzione 2

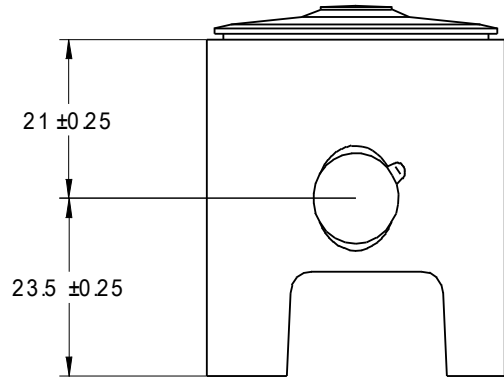
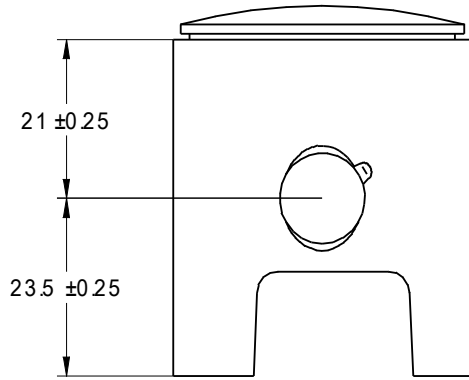

**FOTO DEI PISTONI Lato Mantello**

Opzione 1



Opzione 2



**FOTO DEI PISTONI Lato Superiore**

Opzione 1



Opzione 2



## DISEGNO E QUOTE DEL COLLETTORE DI SCARICO

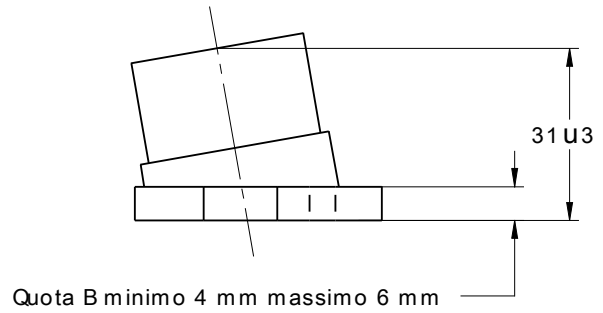
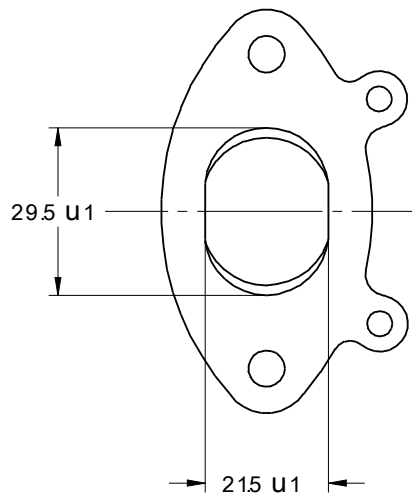

## DISEGNO E QUOTE DELLA FLANGIA TRA COLLETTORE DI SCARICO E CILINDRO

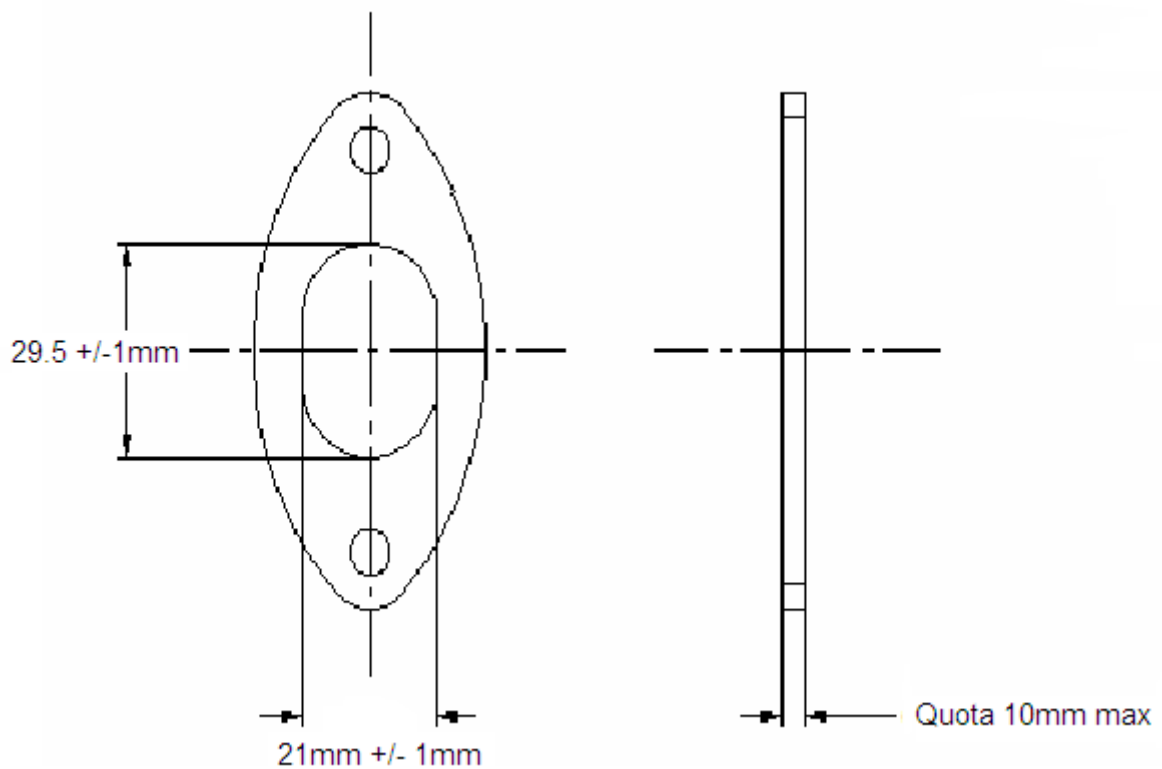



Automobile Club d'Italia

COMMISSIONE SPORTIVA AUTOMOBILISTICA ITALIANA

**SCHEDA VO  
VARIANTE OPZIONE  
60cc.  
MINIKART E BABYKART**

Form. OM/MT/60

N. OMOL.  
06/MT/14  
01/VO/14

Costruttore	LENZOKART SRL
Marca	LKE
Modello	R12
Validità " <u>VO</u> "	01/01/ 2011 – 31/12/ 2014

Pagine 4

### DESCRIZIONE DELLA VO

- 1 - Modifica forma travasi laterali canna cilindro  
*Modification of transfer port shape in cylinder barrel*
- 2 - Modifica profilo condotto di aspirazione cilindro  
*Modification of cylinder inlet duct*
- 3 - Modifica aletta di raffreddamento testata  
*Modification of cylinder head cooling fins*

**\*\*\*N.B.** La VARIANTE OPZIONE va applicata integralmente se utilizzata

**\*\*\*N.B.** *The VARIANT OPTION must be applied in full if used*

Roma li, 30/11/2010

Timbro e Firma della CSAI



Timbro e Firma del Costruttore

**Vecchio Disegno**

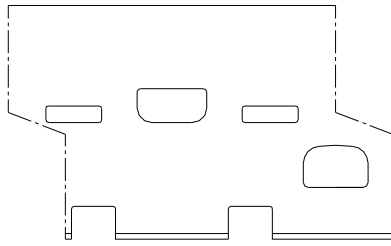

**Nuovo Sistema/Disegno/Quote**

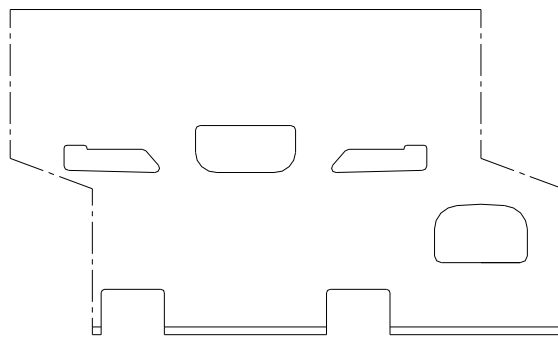

**Vecchio Sistema Disegno**

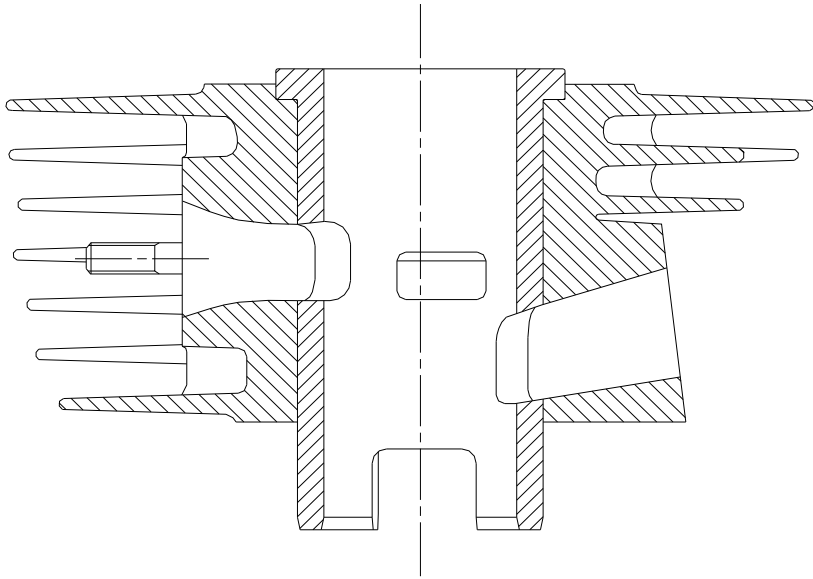

**Nuovo Sistema Disegno**

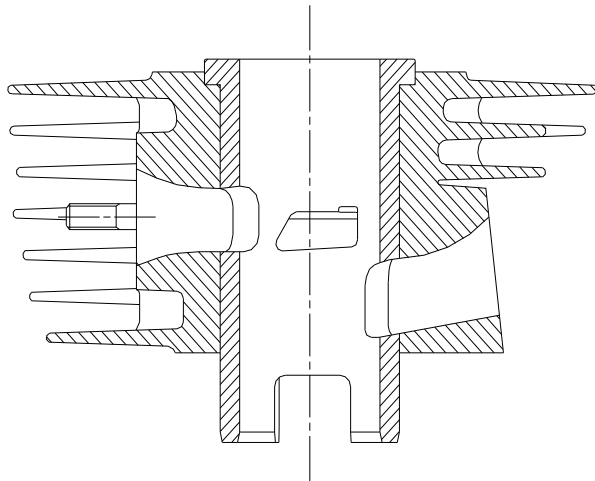

**Vecchio Sistema Foto**



**Nuovo Sistema Foto**

