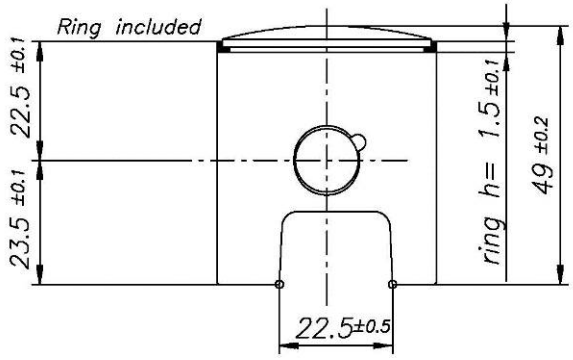
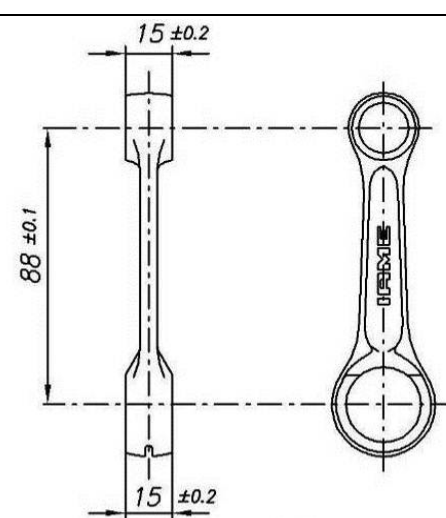

# NORSWIFT 60cc - N

## (NORWAY)

		FEATURES	
		Cylinder volume	59.42 cm <sup>3</sup> (60.00 cm <sup>3</sup> max.)
		Bore	41.80 mm
		Max. theoretical bore	42.00 mm
		Stroke	43.30 mm max.
		Cooling system	Air
		Inlet system	Piston Port
		Number of carbs	1
Tillotson Carburettors HW -	47A Ø15mm (CADETTI CLASS) 34B Ø17mm (MINI CLASS)	Transfers n. cylinder/crankcase	2 / 2
Number of piston rings	1	Inlet / exhaust ports number	1 / 1
Big end conrod ball-bearing diam.	18x24x15	Combustion chamber shape	Spherical
Crankshaft ball-bearing diam.	20x47x14	Selettra ignition	Cod. A-61959N (lim. 12.000 rpm CADETTI CLASS) Cod. A-61959R (lim. 13.500 rpm MINI CLASS)
Small end conrod ball-bearing diam.	12x16x16	Distance between conrod centres	88 mm

DESCRIPTION OF THE MATERIAL		PISTON	
Conrod material	Steel	 <p>Min Weight (ring incl.) 60 g</p>	
Crankshaft material	Steel		
Head material	Aluminium		
Cylinder material	Aluminium		
Liner material	Cast Iron		DISTANCE BETWEEN CONROD CENTERS
Crankcase material	Aluminium		 <p>Min. Weight 80 g</p>
Piston material	Aluminium		
Piston rings material	Cast Iron		
Exhaust muffler material	Sheet-steel		
Ball-bearings	6204 type		

### CRANKSHAFT

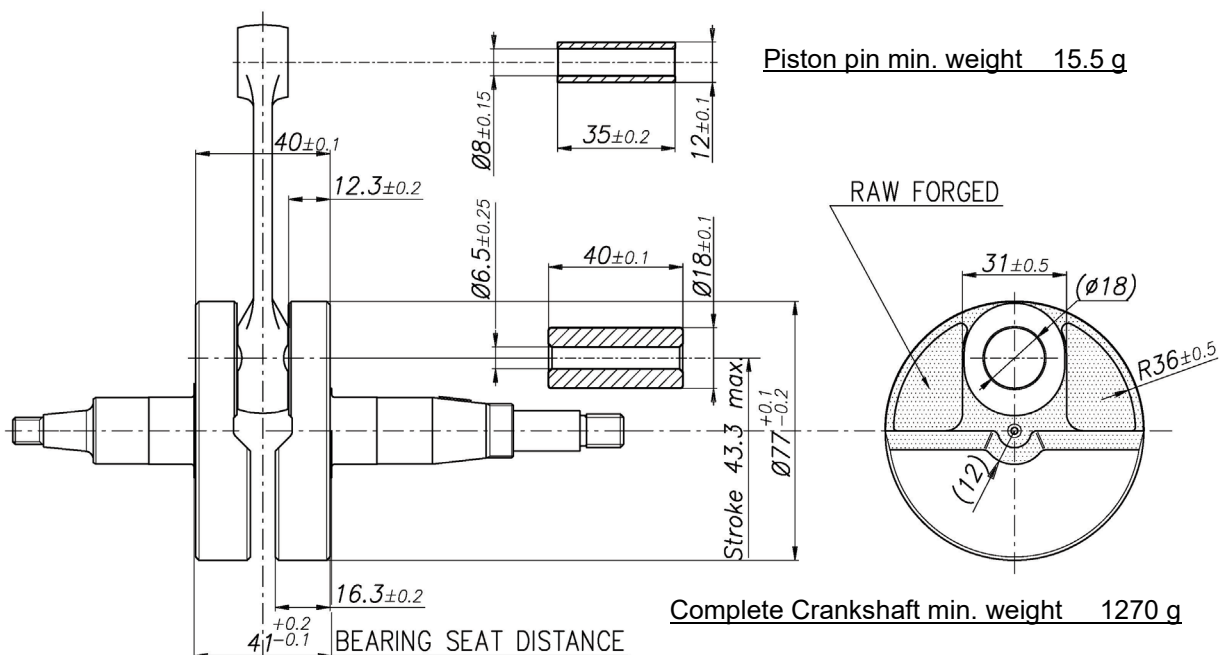

# CYLINDER DEVELOPMENT

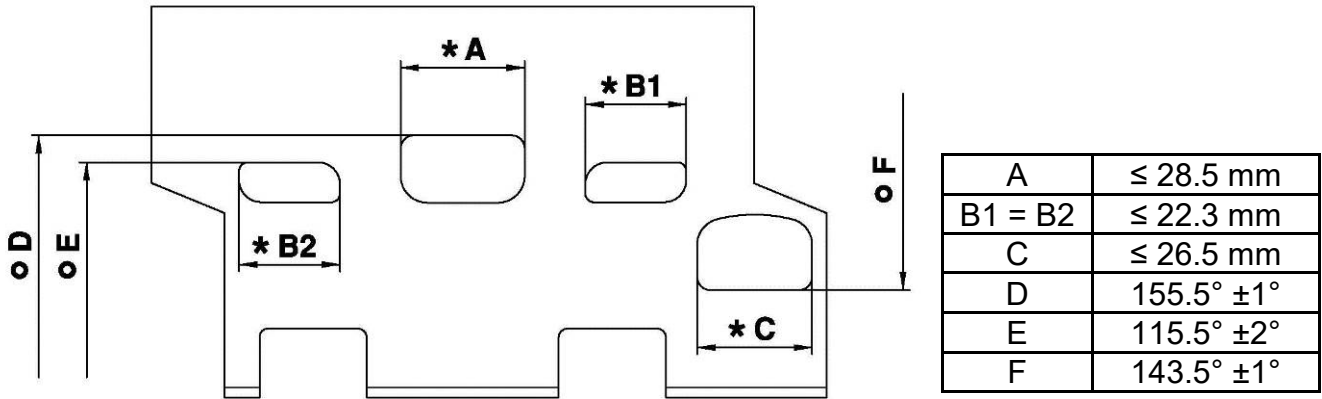

\* CHORDAL READING

o ANGULAR READING BY INSERT A 0.2x5 mm GAUGE

## CYLINDER BASE VIEW

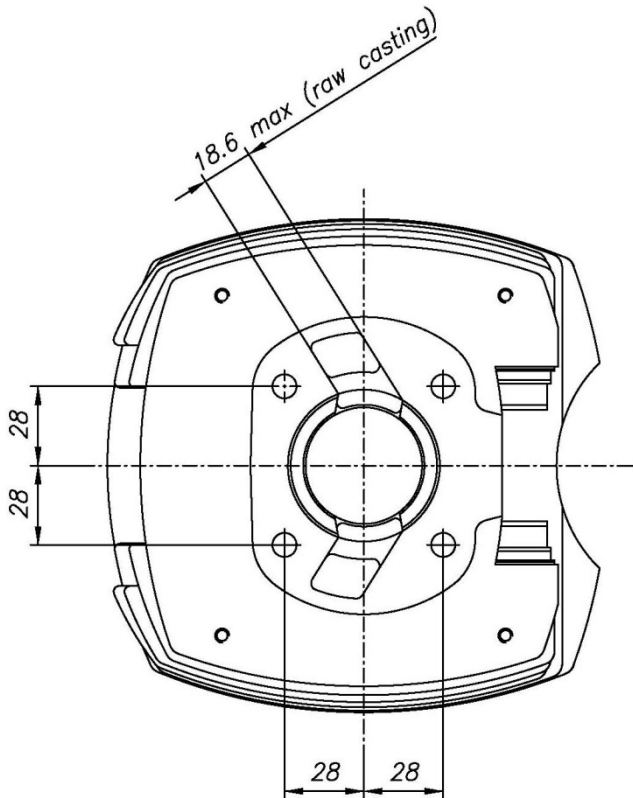

## CYLINDER CROSS SECTION VIEW

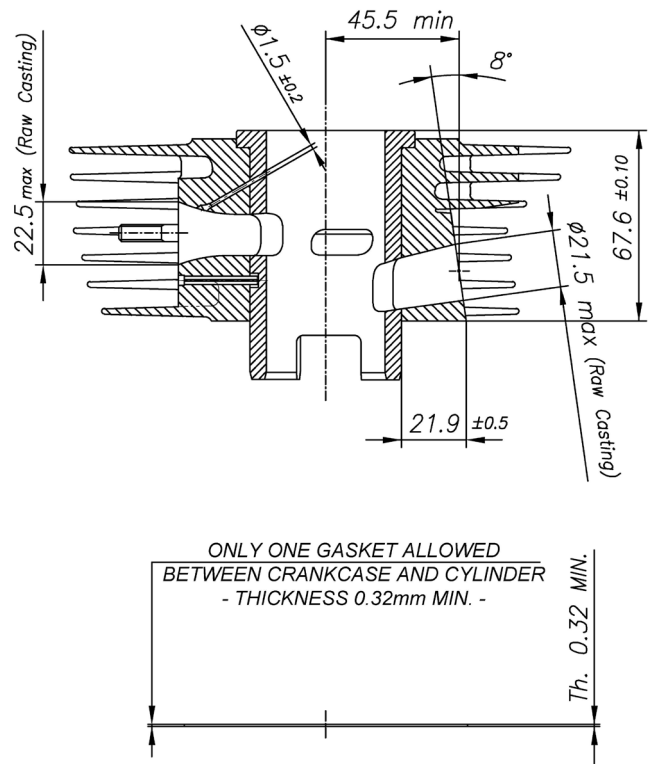

The permitted gasket thickness to use = 0.4mm and 0.5mm

# COMBUSTION CHAMBER VIEW

**COMBUSTION CHAMBER VOLUME = 6.03cm<sup>3</sup> min.**

**SQUISH MIN.= 0.6 mm (measured with Ø1.5mm TIN)**

Combustion chamber volume in the cylinder head  
(with Volumeter and CIK insert):

**7.4 cm<sup>3</sup> min**

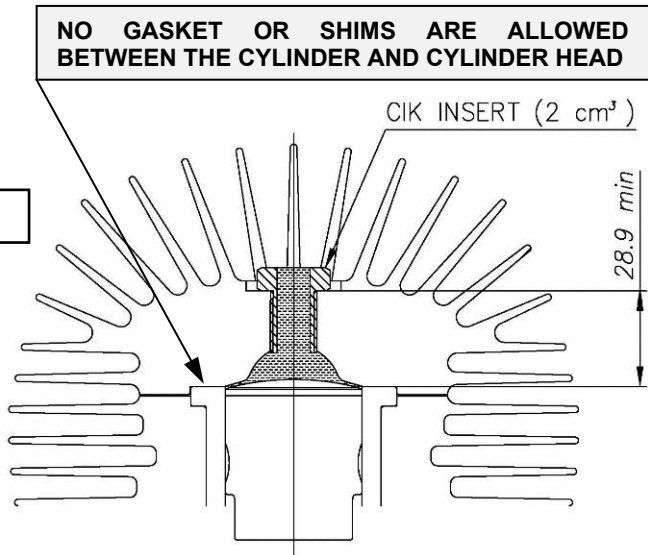

## CRANKCASE INSIDE VIEW

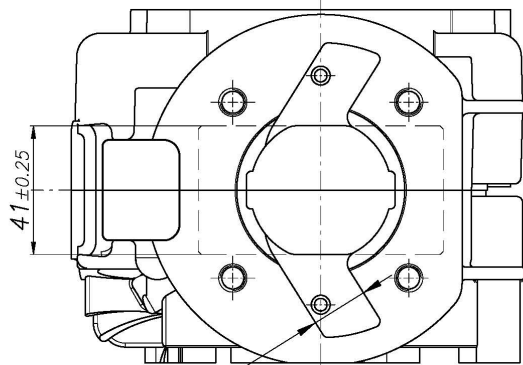
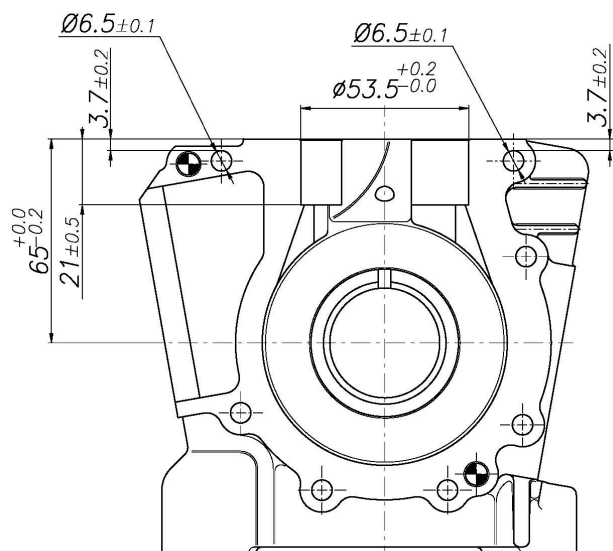

18.3 max  
(RAW CASTING)

## INLET SILENCER

**(CSAI Hom. N° 01/SA/14)**

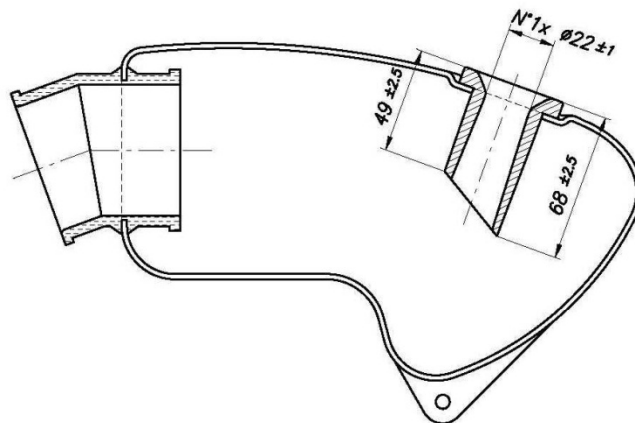

**IN ALTERNATIVE (OPTIONAL)**

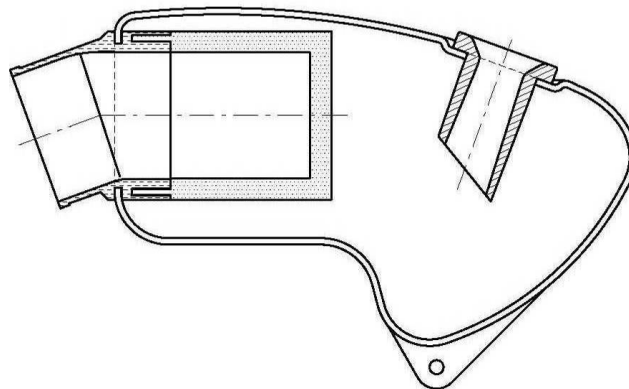

CARBURETTORS, INLET SILENCER SUPPORTS AND EXHAUST MANIFOLDS  
FOR "MINI" VERSION AND "CADETTI" VERSION

**CADETTI Class**

Tillotson HW-47A

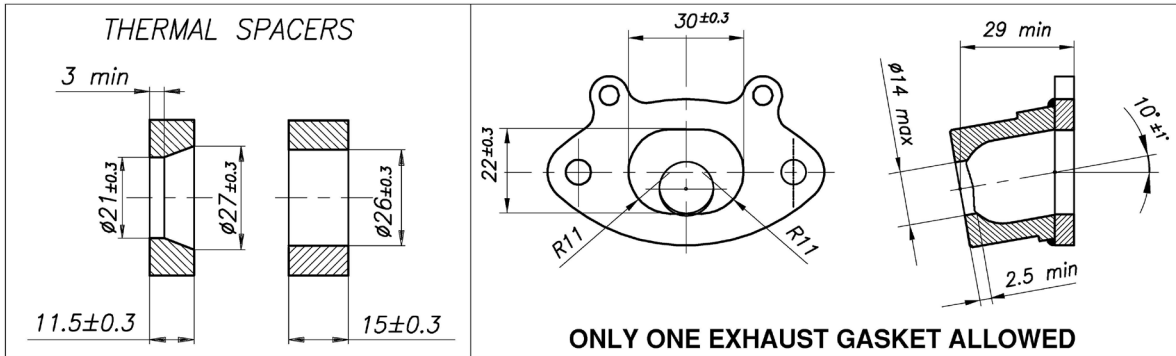
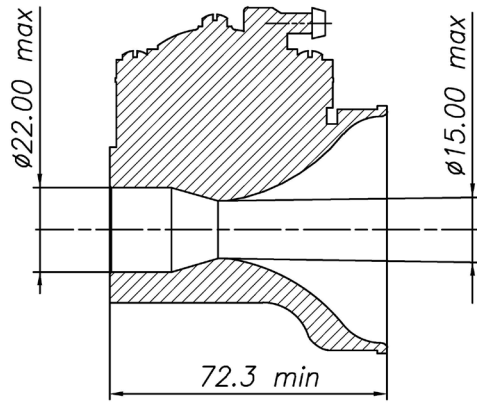

**MINI Class**

Tillotson HW-34B

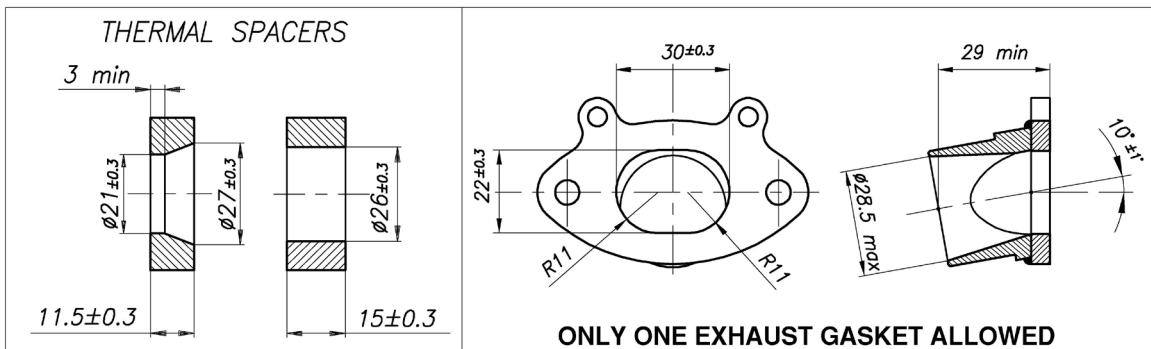
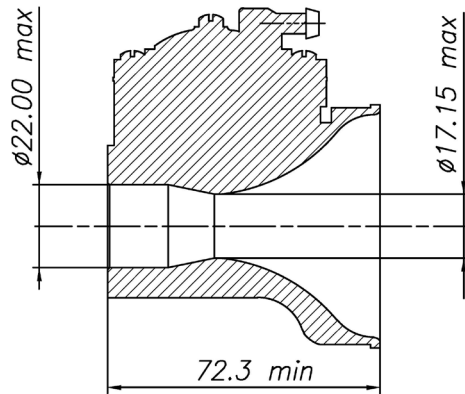
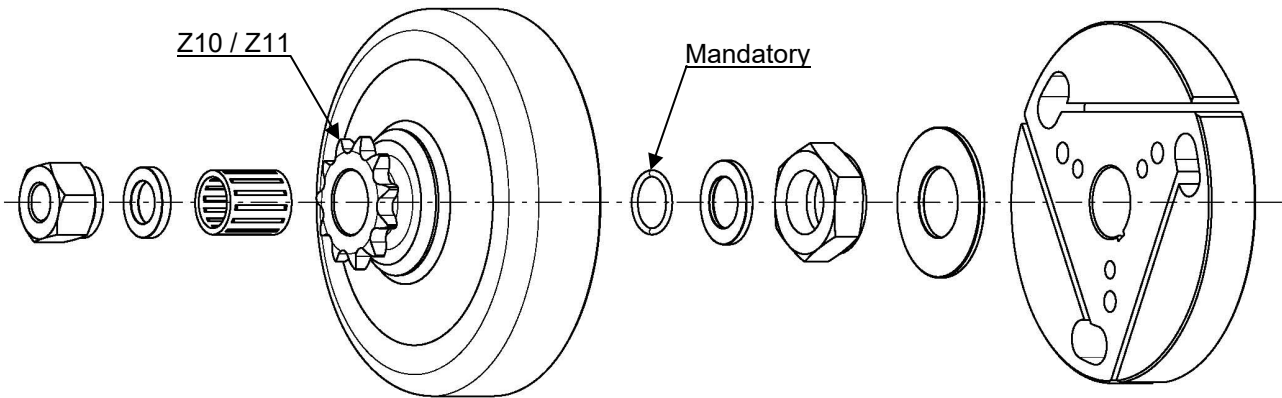

PHOTO IDENTIFICATION MARKING SPONGE FILTER (OPTIONAL)



DESCRIPTION OF THE CLUTCH



The template "N.P." must be used in multiple directions.  
 In case it happen that in a direction "PASS" and another,  
 "DO NOT PASS", the clutch drum is considered regular.

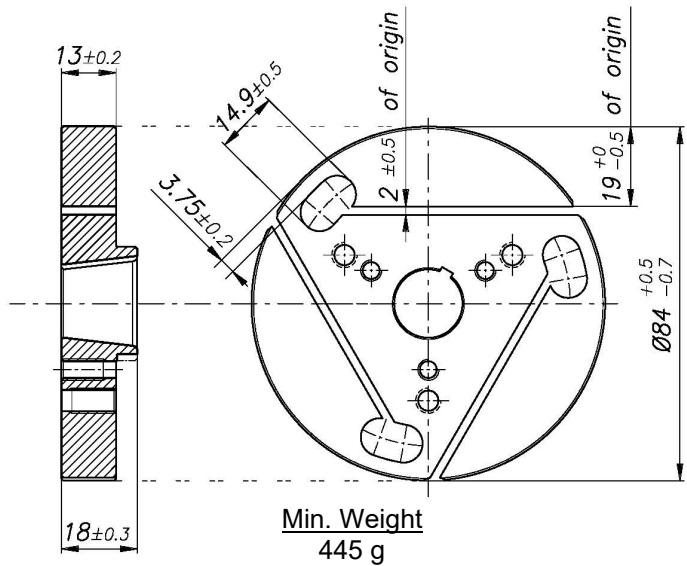
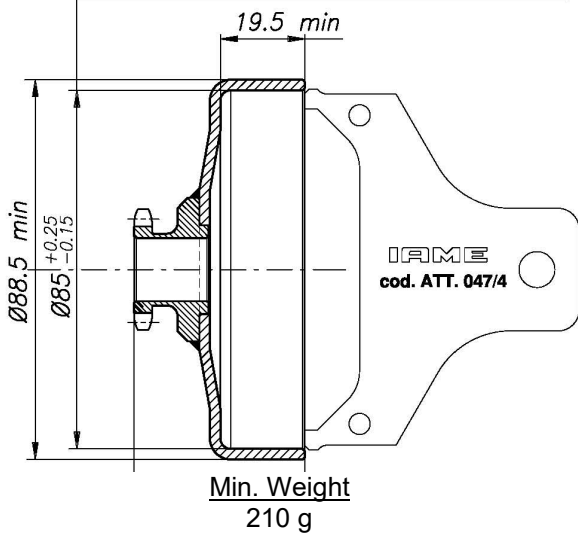

## EXHAUST VIEW AND DIMENSIONS (with and without embossed logo)

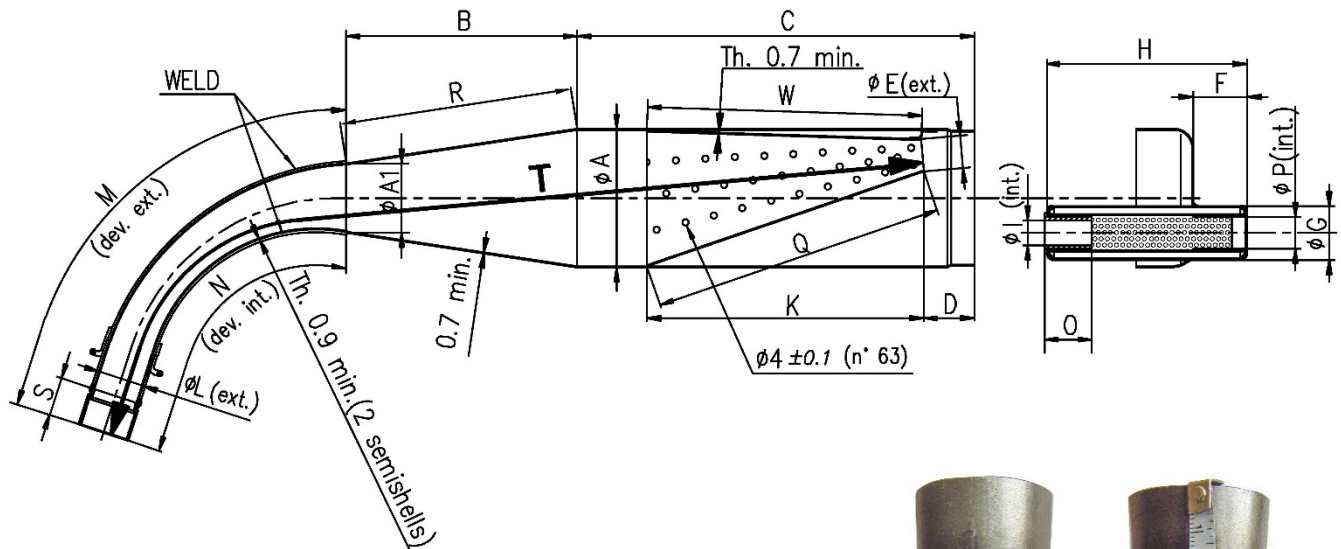

The tape must follow the centerline of the weld at all points

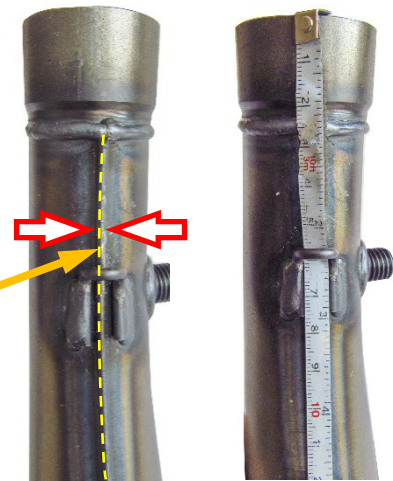

Min. weight 1.250 g

<b>ØA:</b> <u>90 ±1.5 Øext.</u>	<b>D:</b> <u>30 ±2</u>	<b>H:</b> <u>132 ±2</u>	<b>M:</b> <u>265 ±3</u>	<b>R:</b> <u>152 ±3</u>	<b>T:</b> <u>601 ±3</u>
<b>ØA1:</b> <u>45 ±1 Øext.</u>	<b>ØE:</b> <u>20 ±1 Øext.</u>	<b>ØI:</b> <u>17 max Øint.</u>	<b>N:</b> <u>215 ±3</u>	<b>S:</b> <u>25 ±1</u>	
<b>B:</b> <u>150 ±3</u>	<b>F:</b> <u>35 ±2</u>	<b>K:</b> <u>181 ±3</u>	<b>O:</b> <u>30 min.</u>	<b>Q:</b> <u>192 ±3</u>	
<b>C:</b> <u>260 ±3</u>	<b>ØG:</b> <u>35 ±1 Øext.</u>	<b>ØL:</b> <u>31 ±1.5 Øext.</u>	<b>ØP:</b> <u>21 ±1 Øint.</u>	<b>W:</b> <u>181 ±3</u>	

### ATTENTION:

The dimensions “**M**”, “**N**” and “**T**” must be taken by steel tape measure 6mm wide.

The dimensions “**M**” and “**N**” must be taken on the weld centerline.

The dimensions “**Q**” and “**W**” must be taken by steel tape measure 12mm wide

ALTERNATIVE EXHAUST with embossed logo



MARKING

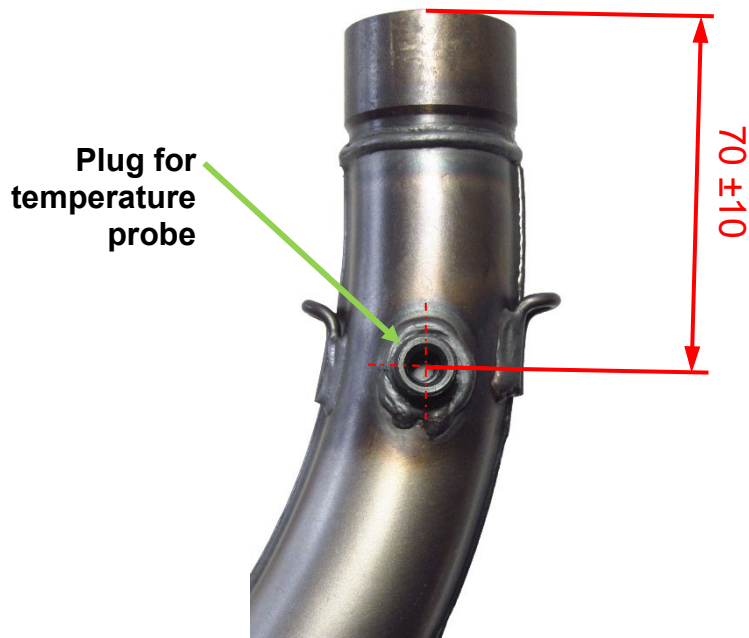



# IGNITION PHOTO IDENTIFICATION MARKING



Min Weight  
362 g

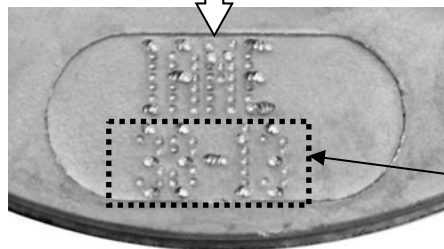

**VARIABLE**

CADETTI CLASS - H.T. COIL PHOTO IDENTIFICATION MARKING – cod. A-61959N

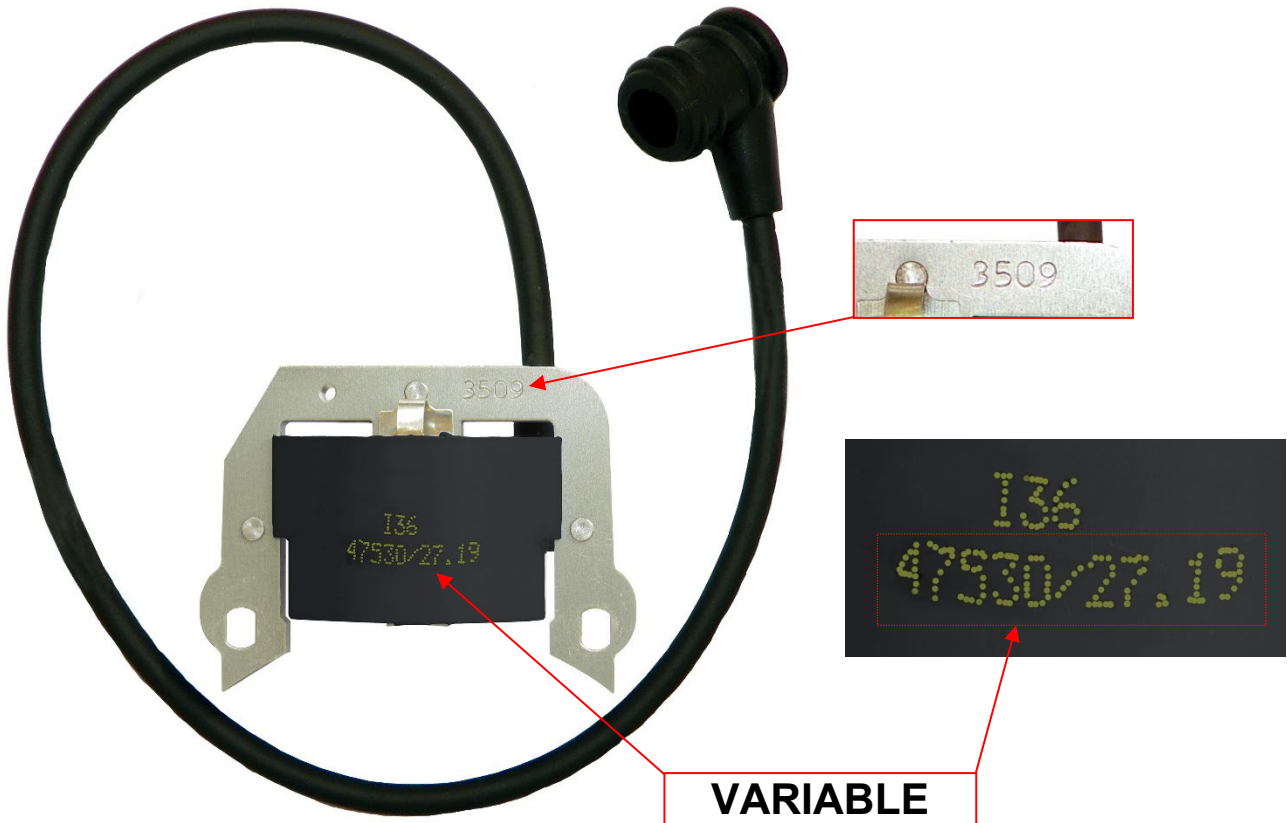

MINI CLASS - H.T. COIL PHOTO IDENTIFICATION MARKING – cod. A-61959R

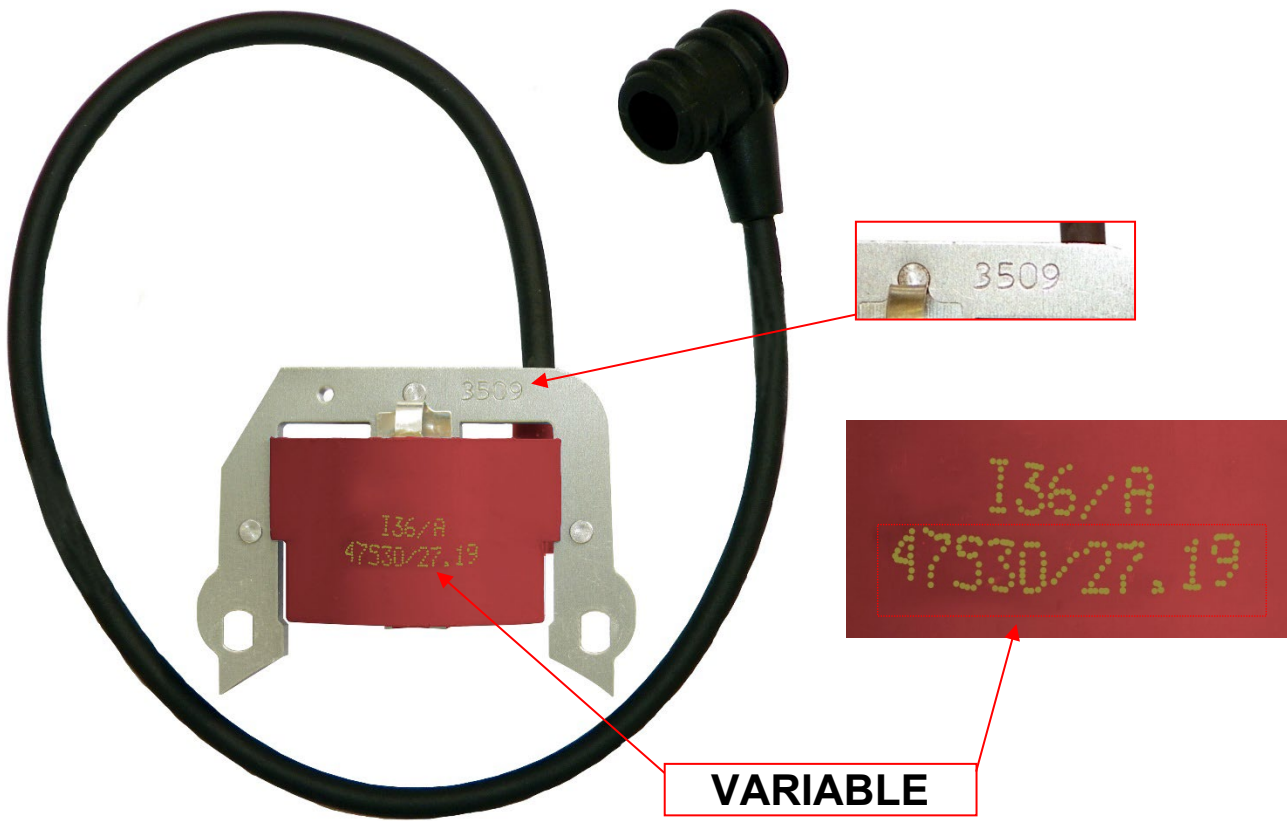

# SCHEME FOR ADVANCE CONTROL – CADETTI CLASS

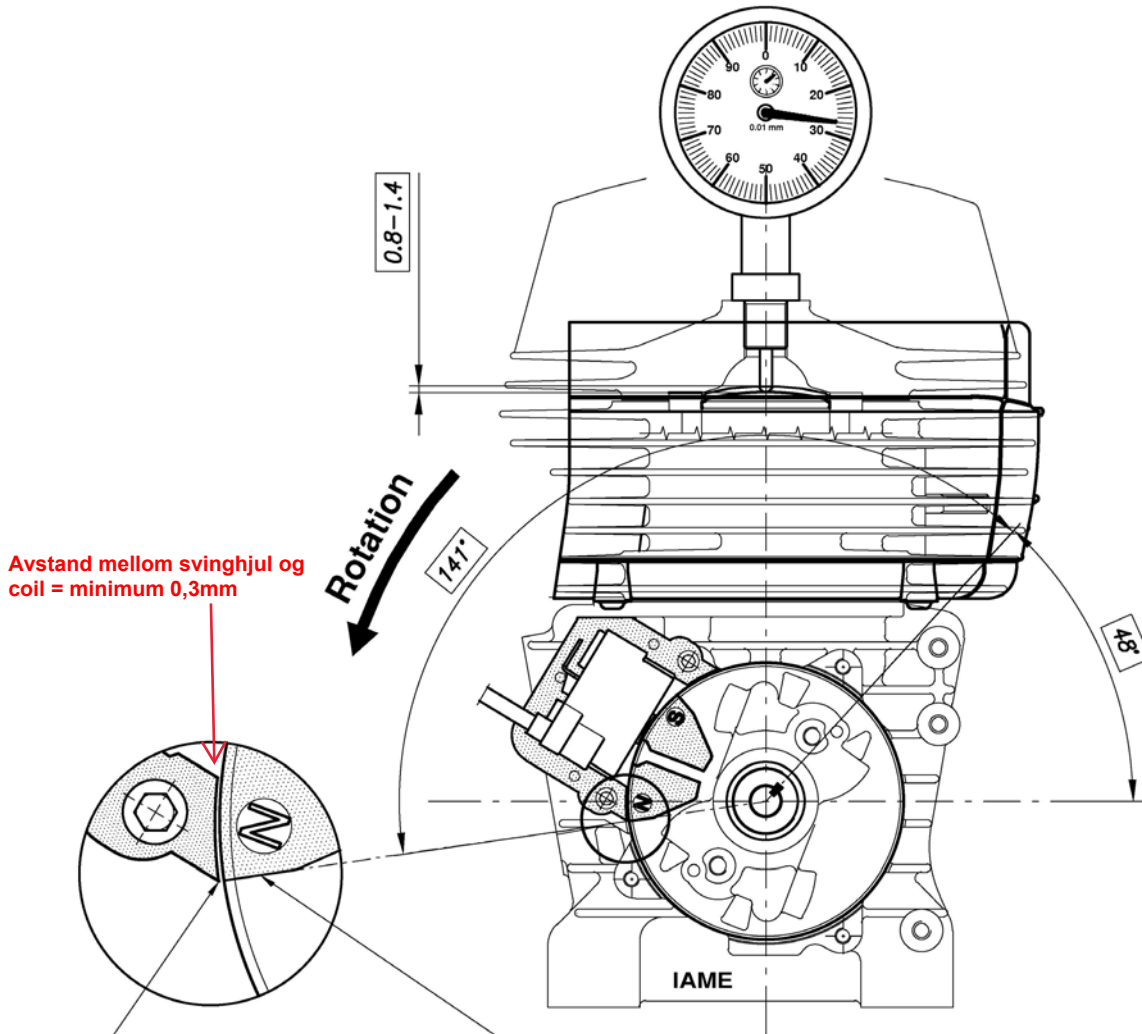

\* ALIGN THE ROTOR MAGNETO END ON THE IGNITION COIL END AS SHOWN.

## ADVANCE CURVE GRAPHS

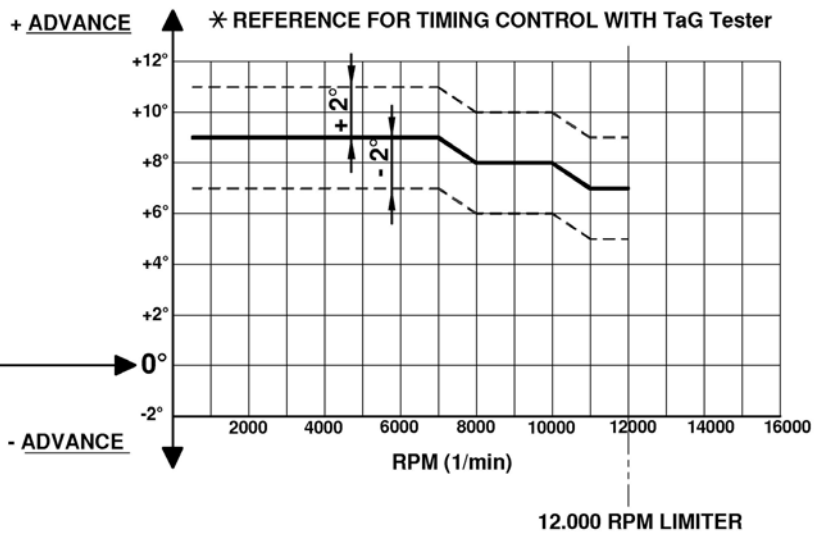

# SCHEME FOR ADVANCE CONTROL – MINI CLASS

Avstand mellom svinghjul og coil = minimum 0,3mm

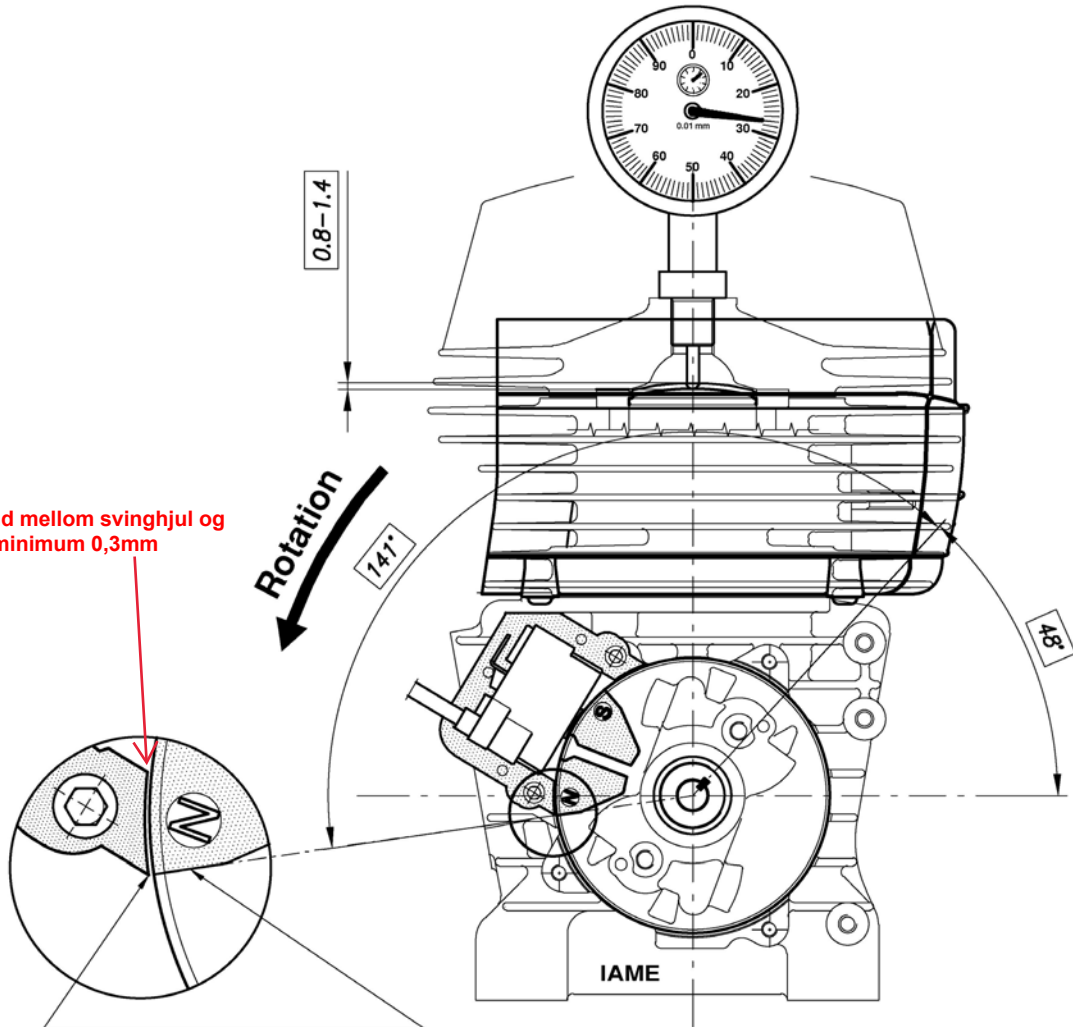

\* ALIGN THE ROTOR MAGNETO END ON THE IGNITION COIL END AS SHOWN.

## ADVANCE CURVE GRAPHS

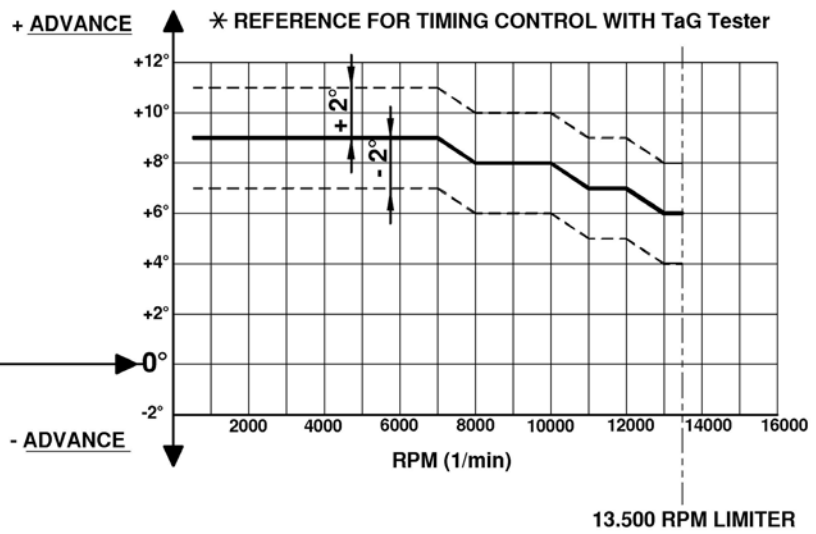

CHECKING DIMENSIONS OF IGNITION-CRANKSHAFT CONNECTION

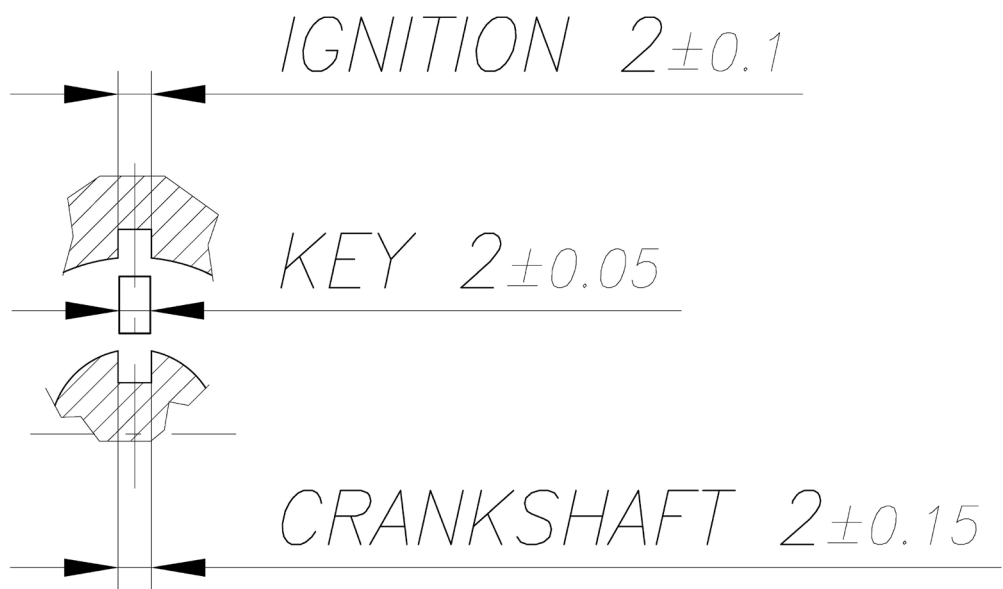

# CYLINDER IDENTIFICATION MARKING

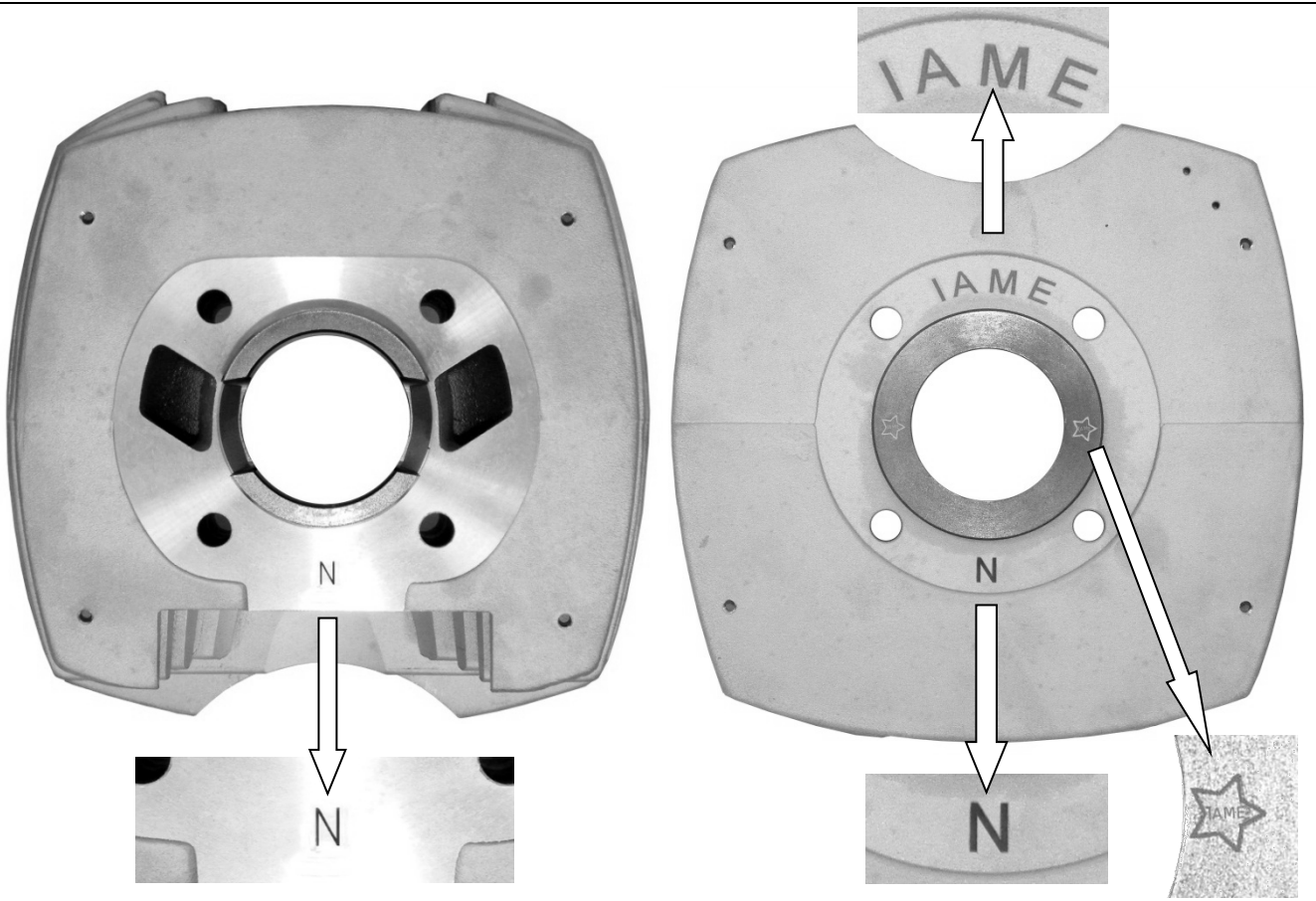

## CRANKCASE IDENTIFICATION MARKING

## HEAD IDENTIFICATION MARKING

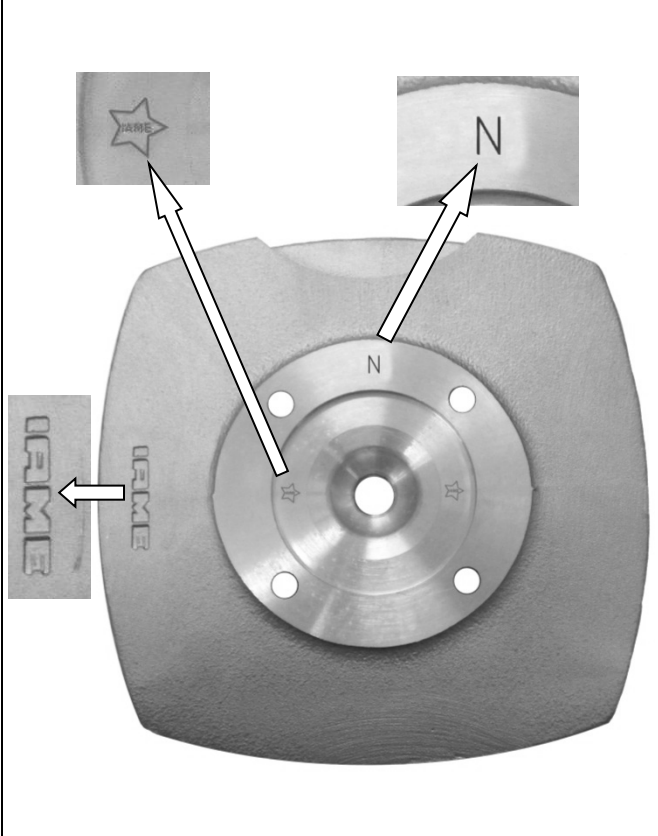
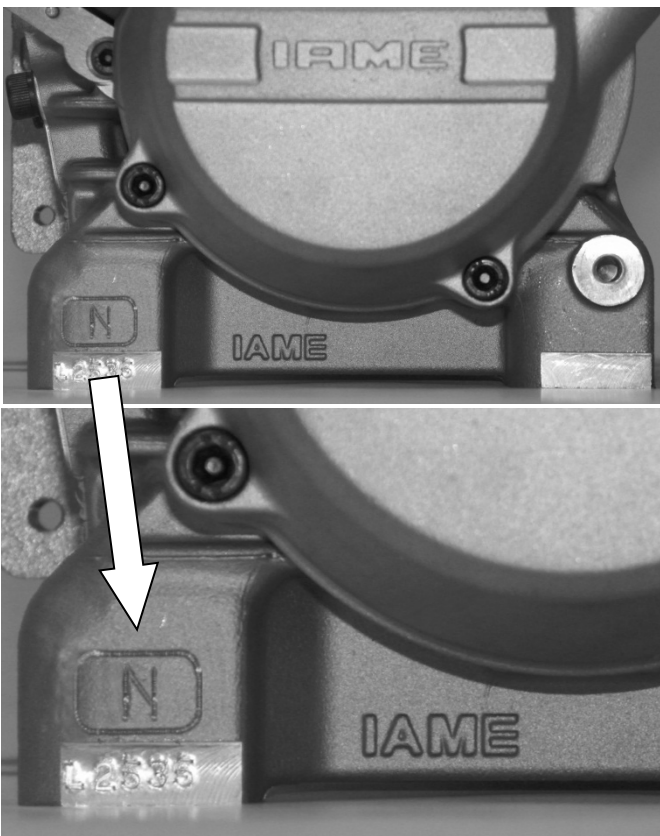

**"IT1" PISTON TYPES IDENTIFICATION**  
(dimensions and weight are the same for both types)

**CURRENT**

**ALTERNATIVE**

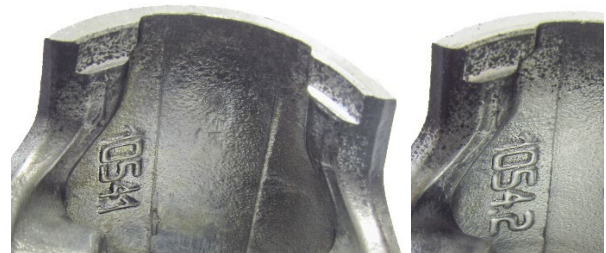
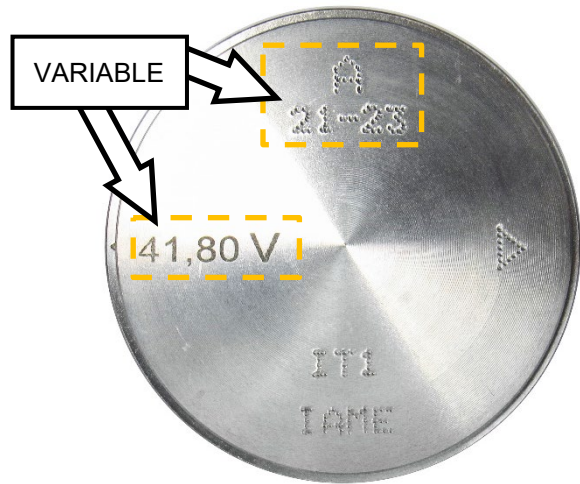
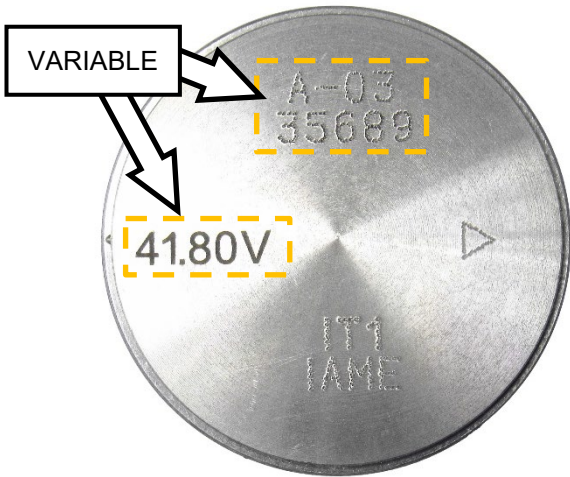

EXHAUST without embossed logo



CONROD IDENTIFICATION MARKINGS

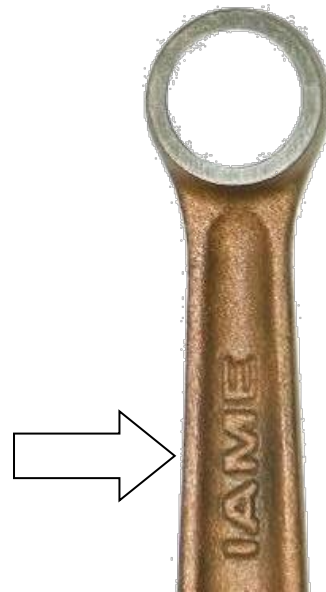

CLUTCH HUB IDENTIFICATION MARKING

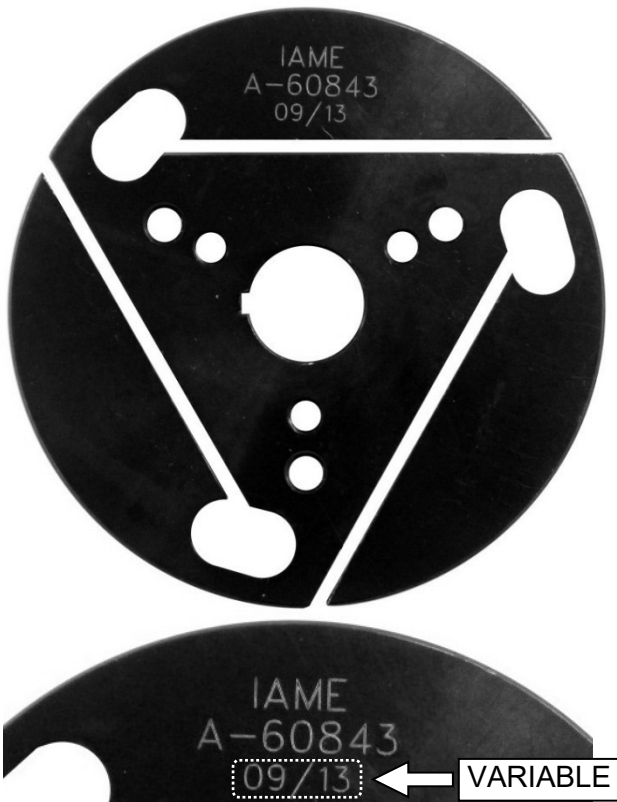

CLUTCH DRUM IDENTIFICATION MARKING





# CRANKSHAFT PHOTOS

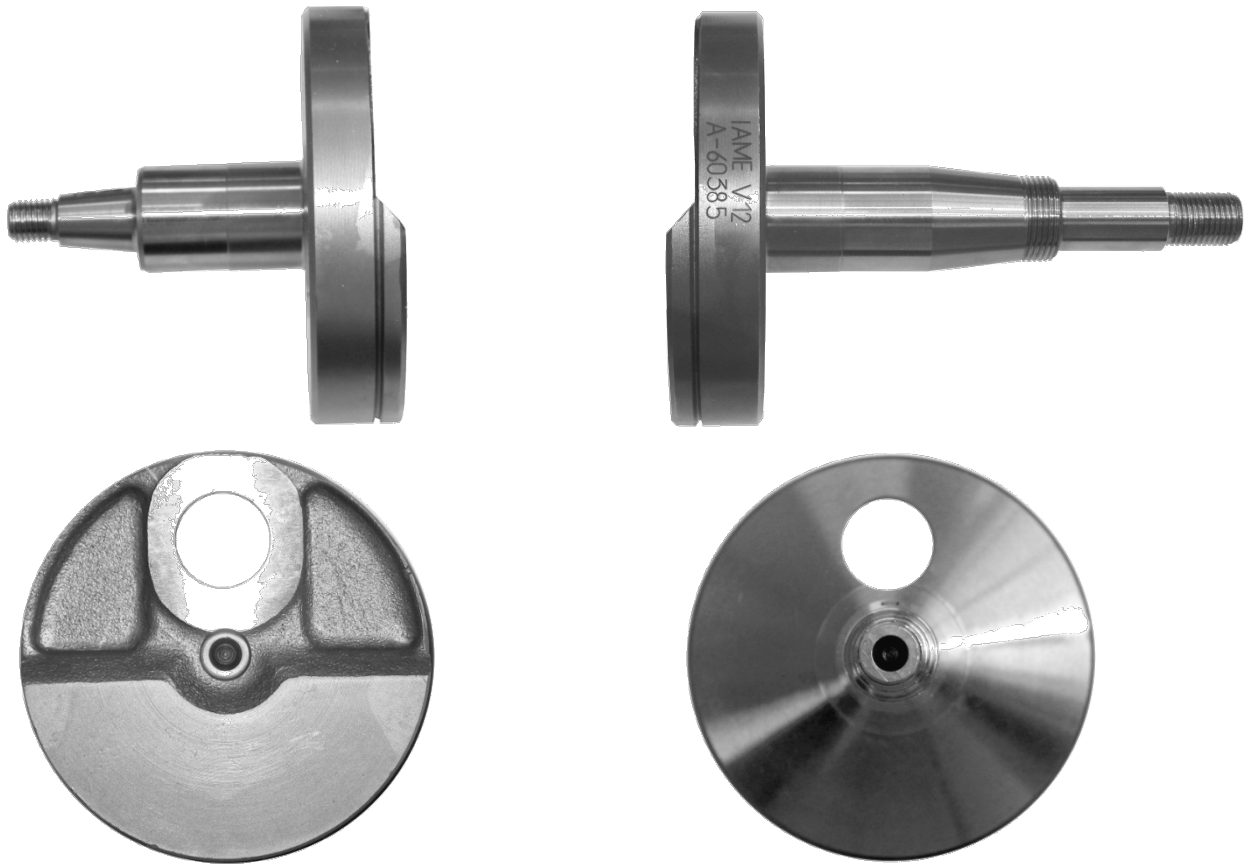

## CRANKSHAFT IDENTIFICATION MARKING

## COMPLETE CRANKSHAFT DETAIL

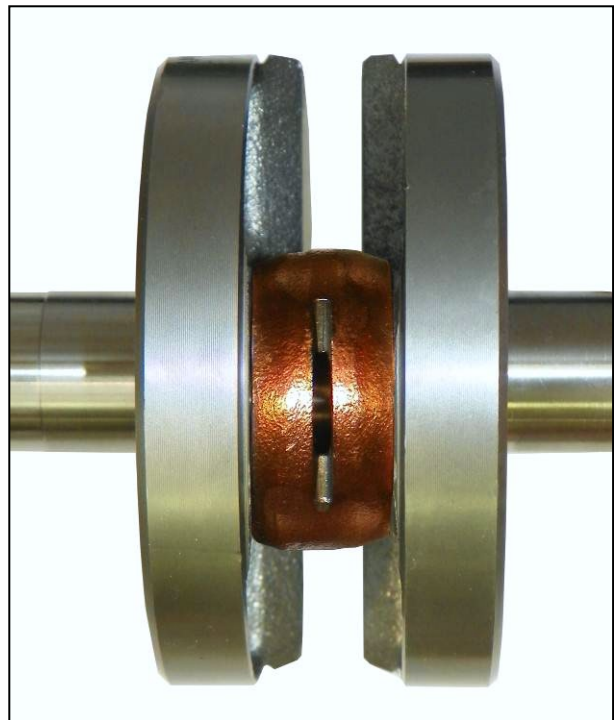

BALL BEARING TYPES IDENTIFICATION MARKING

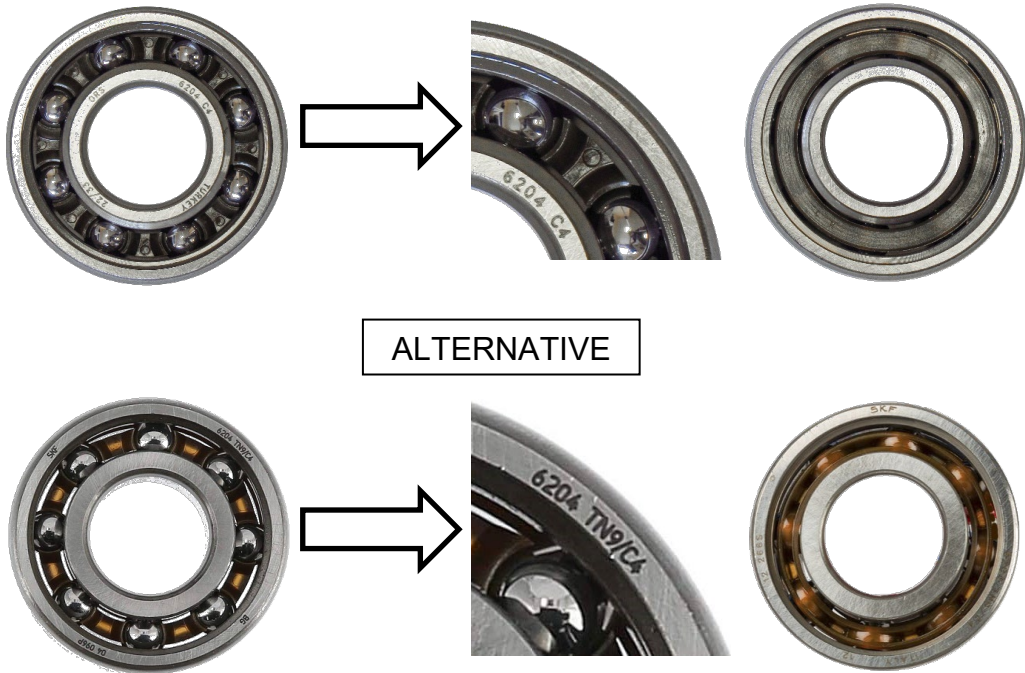

PHOTO IDENTIFICATION OF CONROD – TYPES ALTERNATIVE

TYPE 1



TYPE 2



PHOTO IDENTIFICATION OF PULLEY – TYPES ALTERNATIVE

TYPE 1 – PLASTIC

VARIABLE

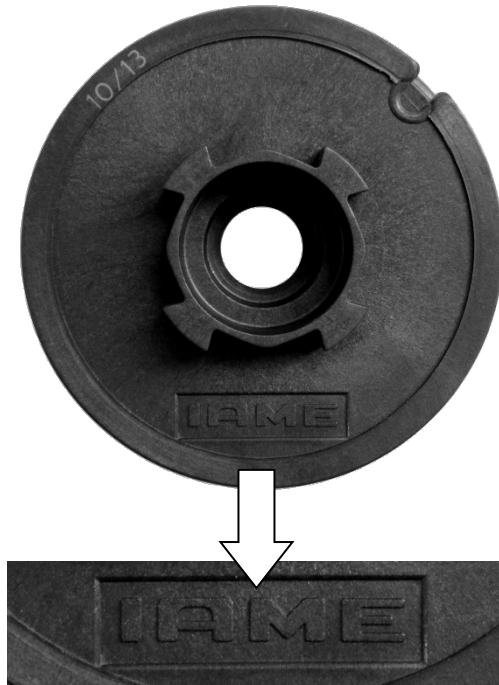
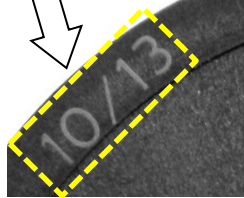

TYPE 2 - ALUMINUM

VARIABLE

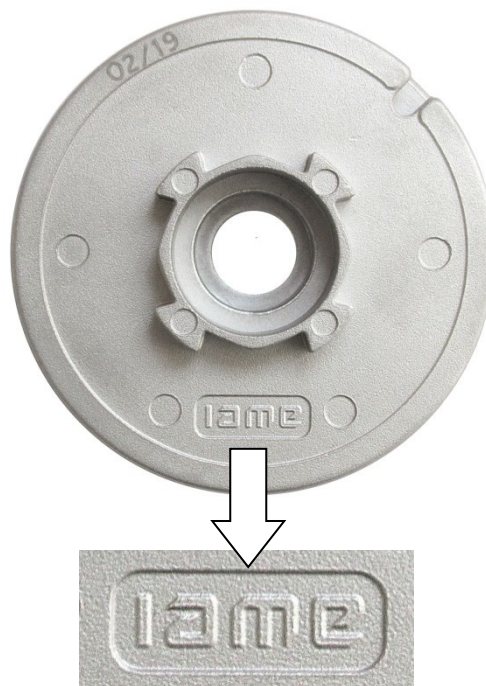

# ALTERNATIVE IGNITION ROTOR

TYPE 1

TYPE 2

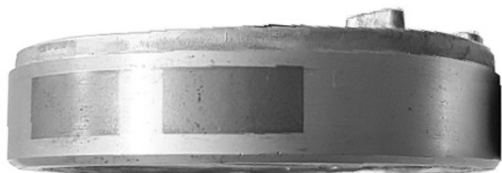

**PARTICULARS WITH ALTERNATIVE NEW LOGO "IAME"**

CYLINDER

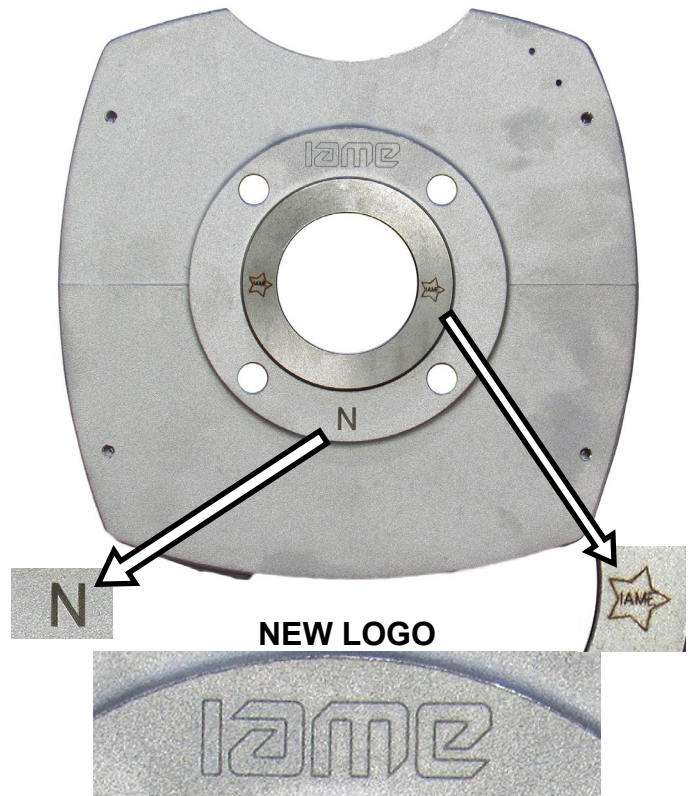
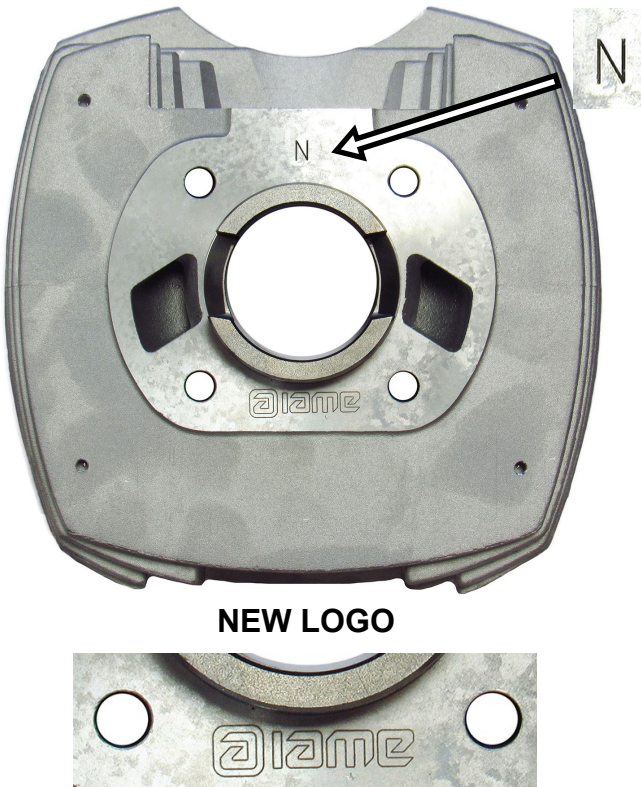

CYLINDER HEAD

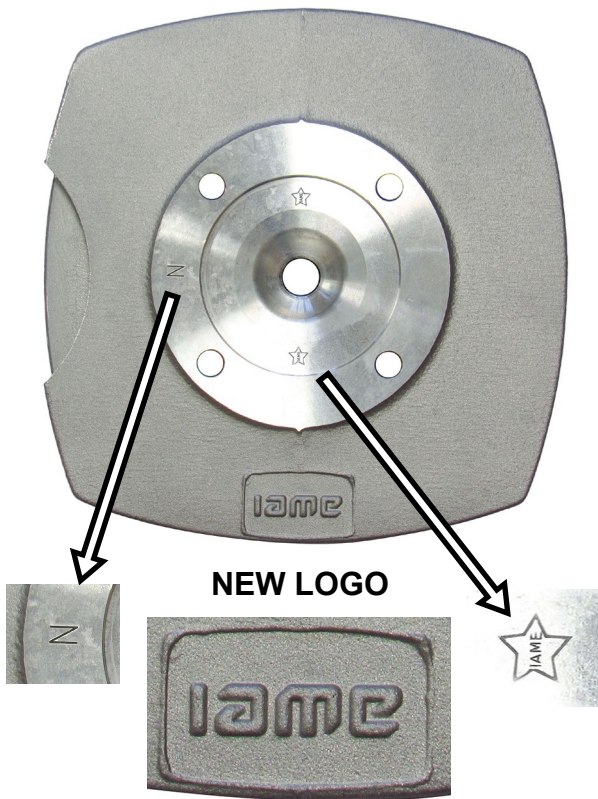

INLET FILTER



**FROM 2025 ON**

**CYLINDER CROSS SECTION – ALTERNATIVE CYLINDER LINER LOCK PIN**

**CURRENT PIN (SPRING PIN)**

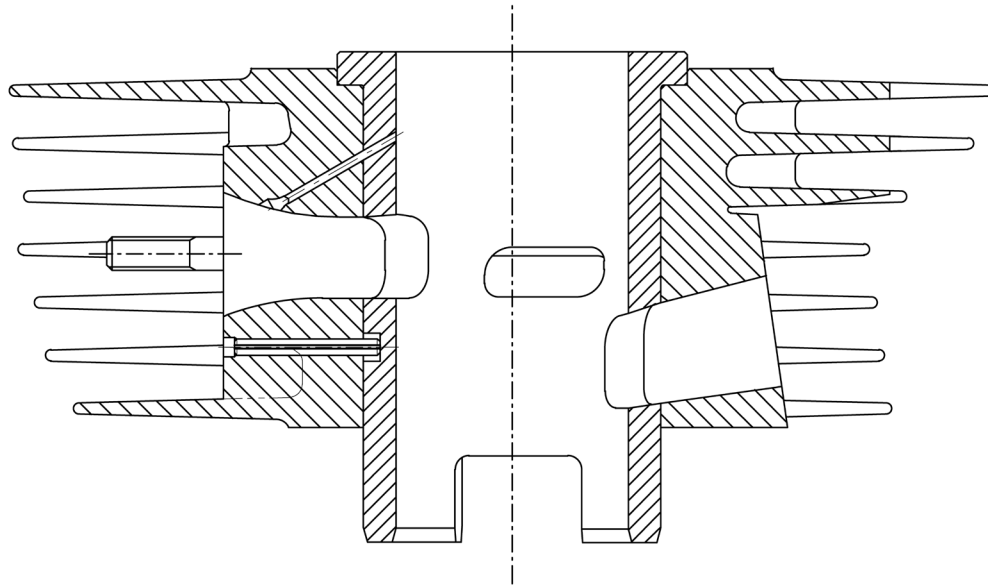

**ALTERNATIVE PIN (GROOVED PIN)**

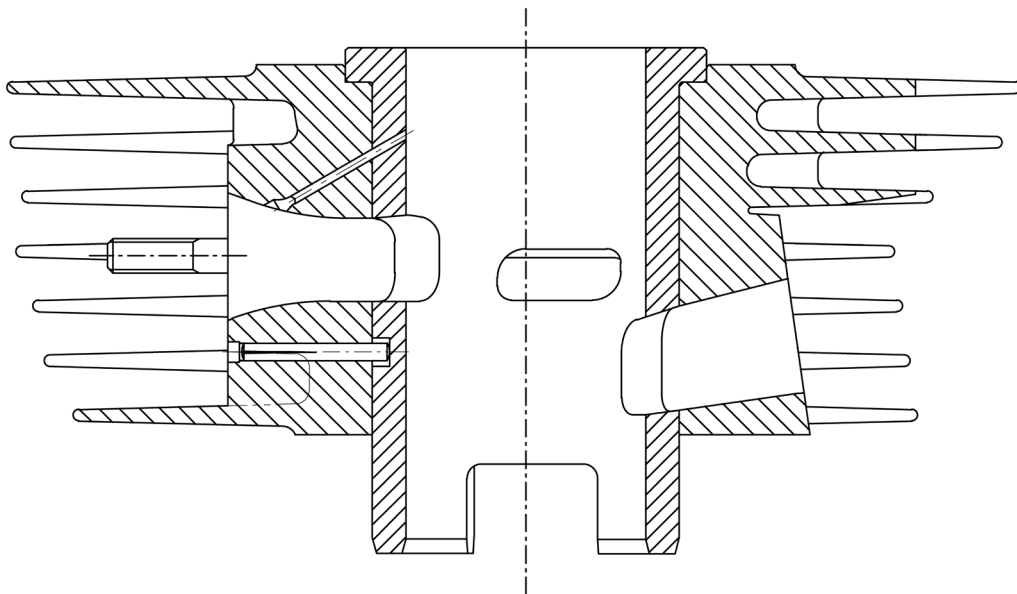

**FROM 2025 ON**

CYLINDER IDENTIFICATION – ALTERNATIVE CYLINDER LINER LOCK PIN

CURRENT PIN

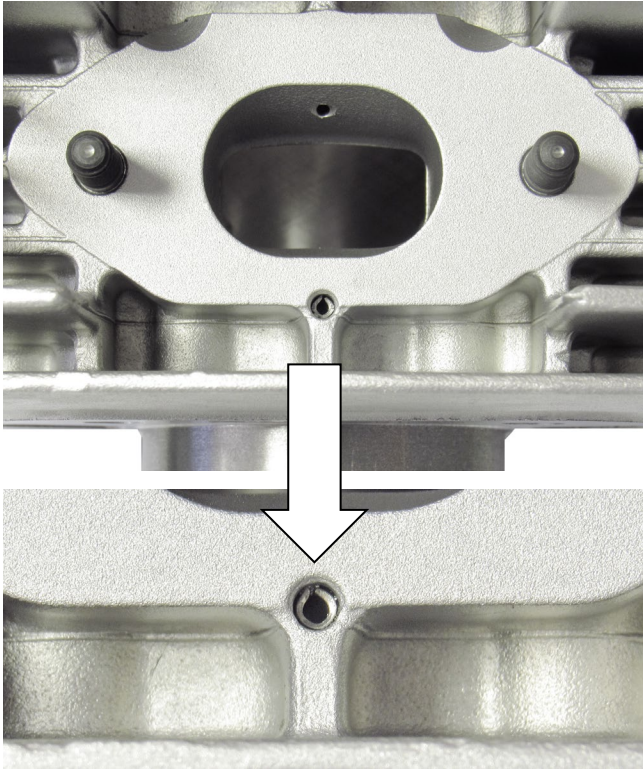

SPRING PIN

ALTERNATIVE PIN

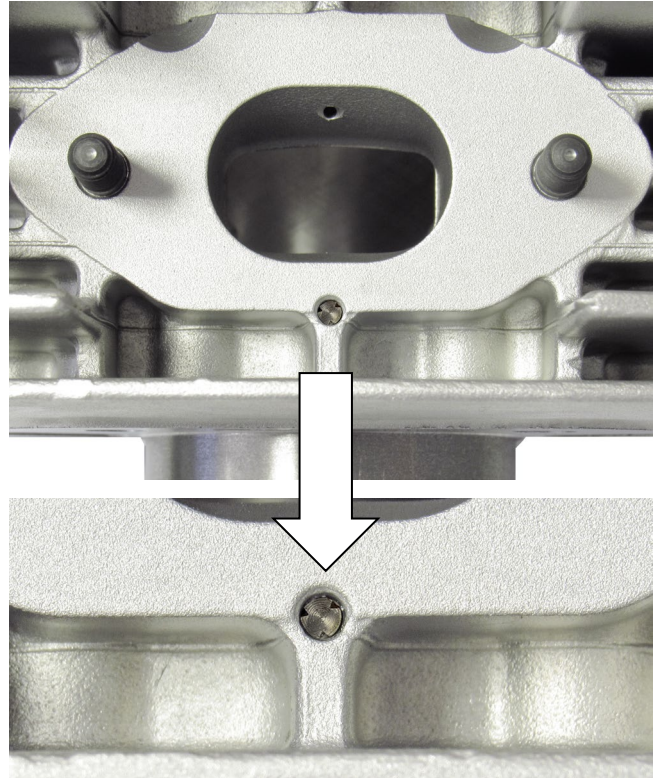

GROOVED PIN

**PARTICULARS WITH ALTERNATIVE NEW LOGO "IAME"**

**SEMICARTER IGNITION SIDE**

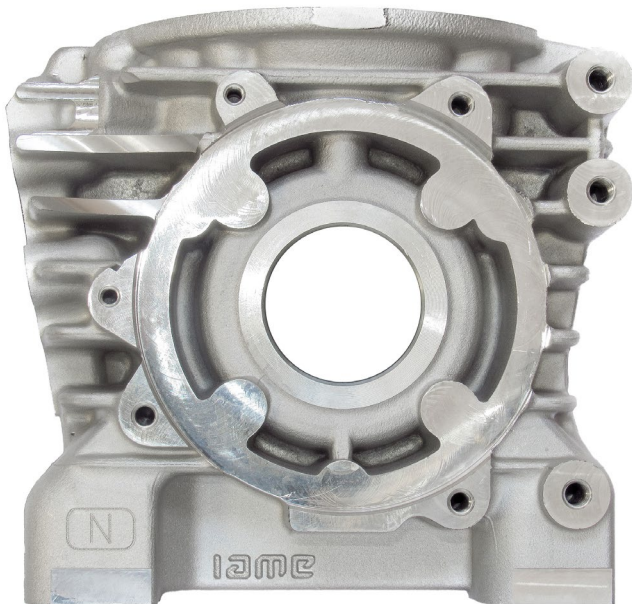

**NEW LOGO**



**SEMICARTER TRANSMISSION SIDE**

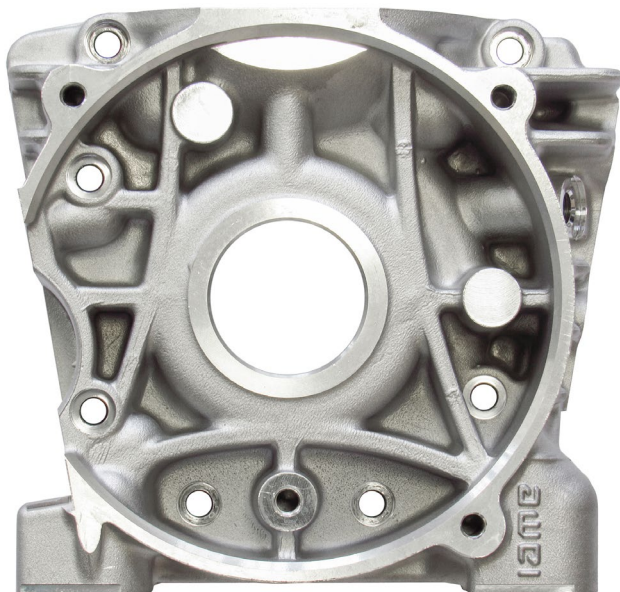

**NEW LOGO**





COMPONENTS WITH ALTERNATIVE NEW LOGO "IAME"

RECOIL COVER



NEW LOGO



CLUTCH COVER



NEW LOGO



EXHAUST without embossed logo



NEW LOGO



**THE OTHER COMPONENTS OF ENGINE THAT ARE MARKED (LASER OR PUNCHING) UNTIL TODAY WITH LOGO OR WRITTEN "IAME"**

I A M E

or

**IAME**

**NOW COULD BE MARKED WITH NEW LOGO "IAME"**

I a m e

or

ⓐ I a m e

or

ⓐ

## CHECKING TOOLS

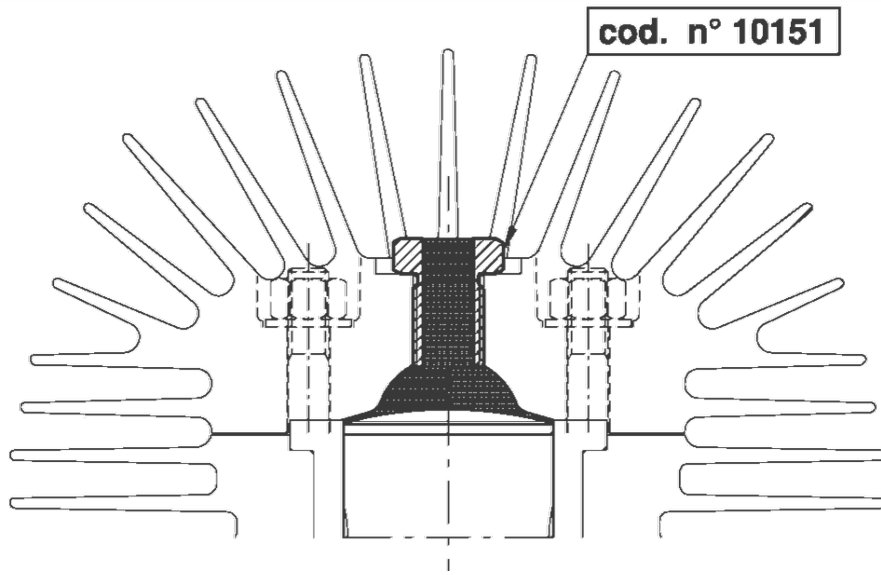

**WITH PISTON AT T.D.C. + INSERT**

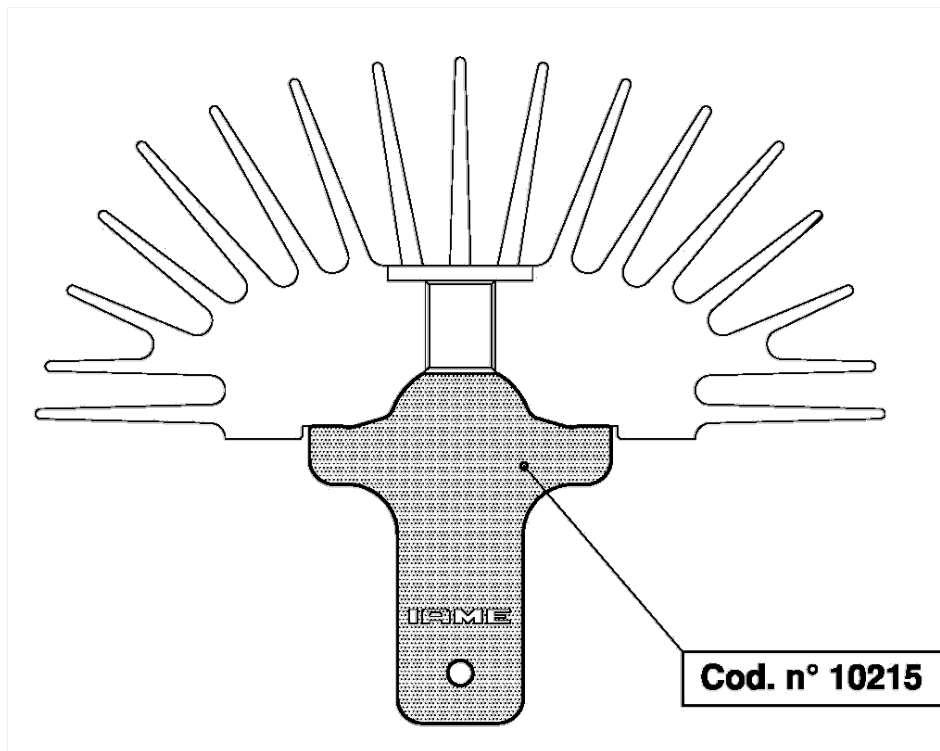

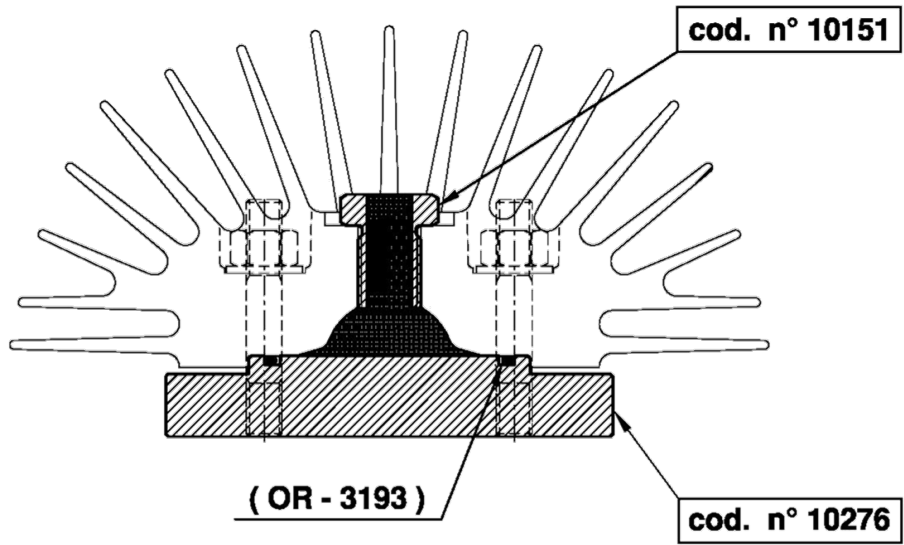

**WITH VOLUMETER + INSERT**

**TOOL IAME Cod. 10194**

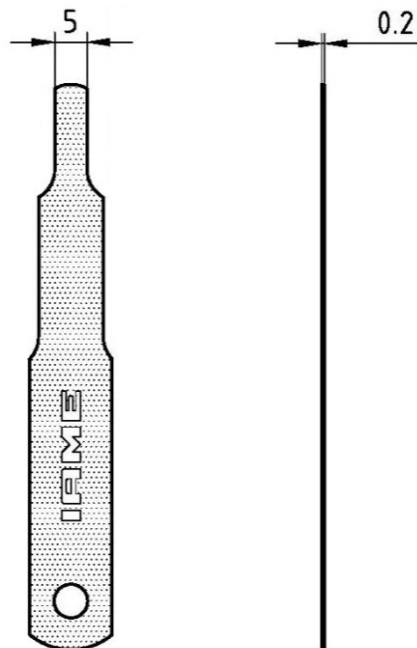

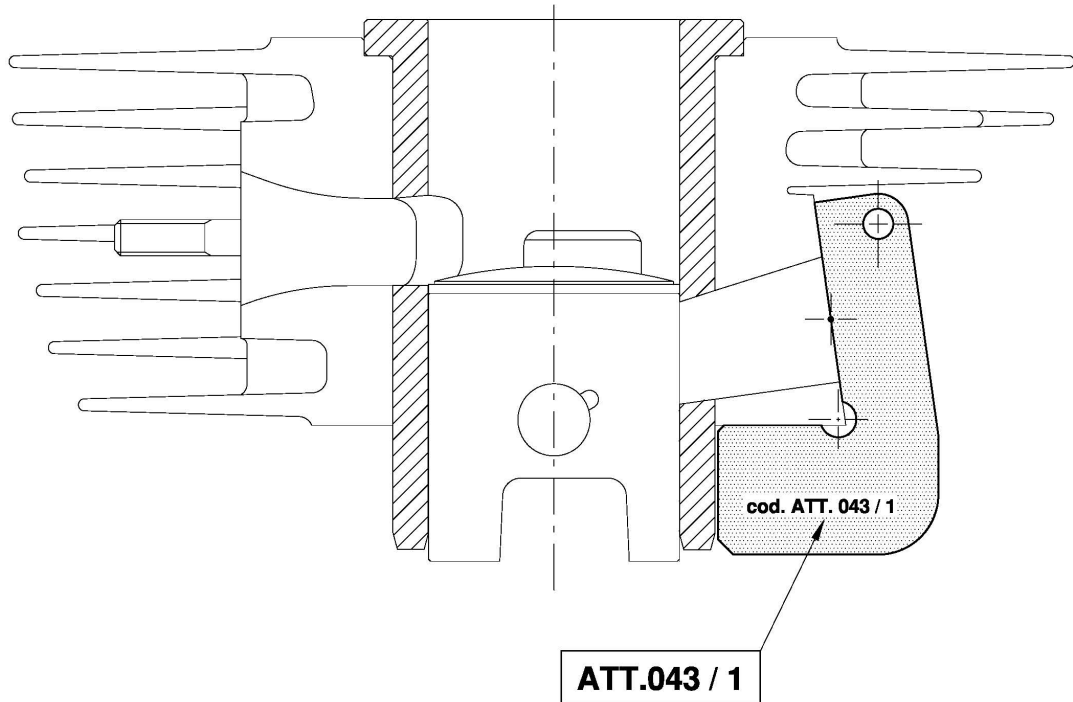

**CHECK THAT THE GAUGE DOESN'T TOUCH THE LINER**

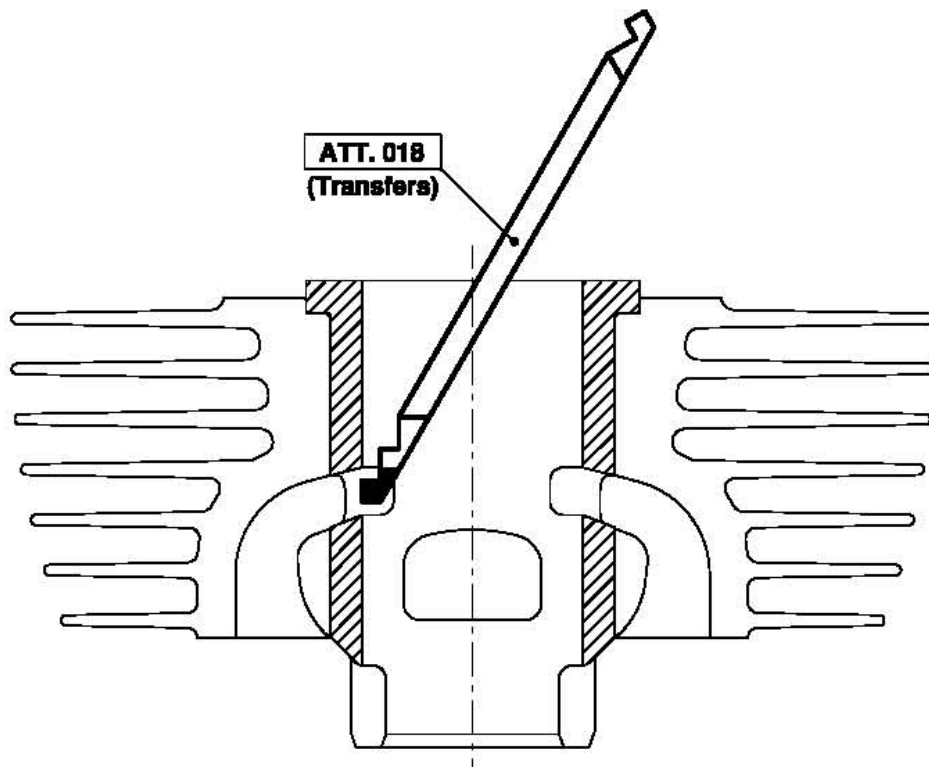

**CHECK THAT THE TOOL DOES NOT ENTER INTO THE TRANSFERS DUCT.**

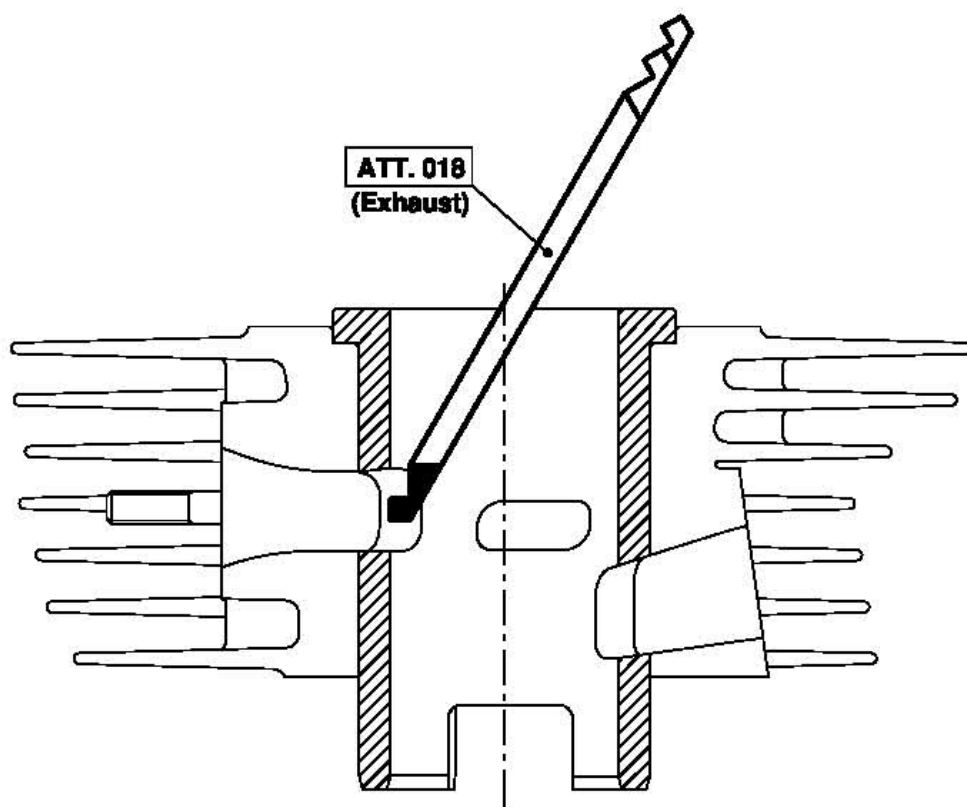
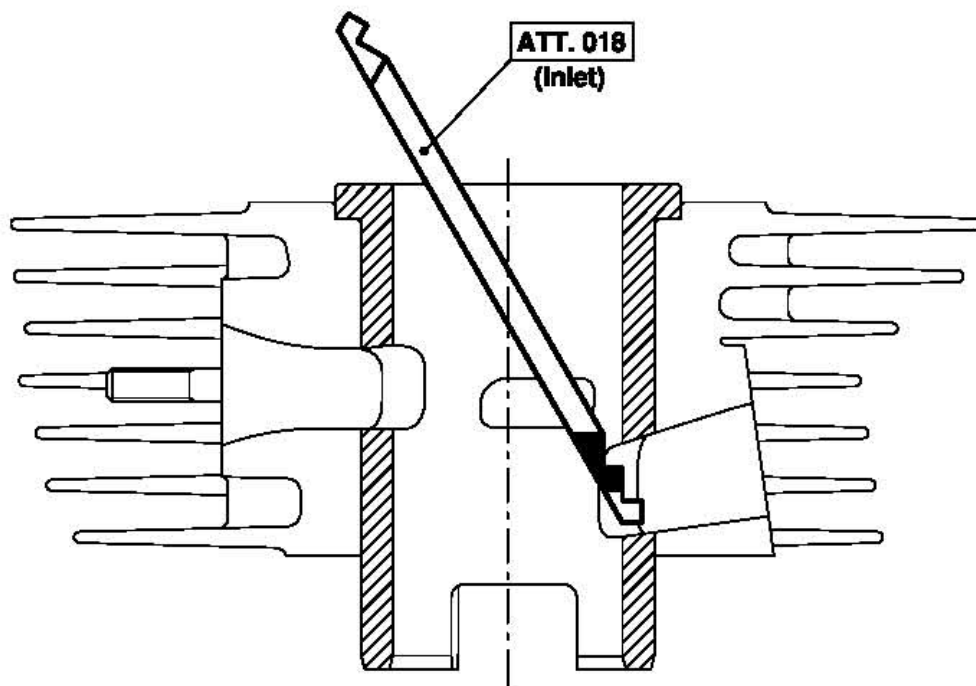

**CHECK THAT THE TOOL DOES NOT ENTER INTO THE INLET AND EXHAUST PORTS.**

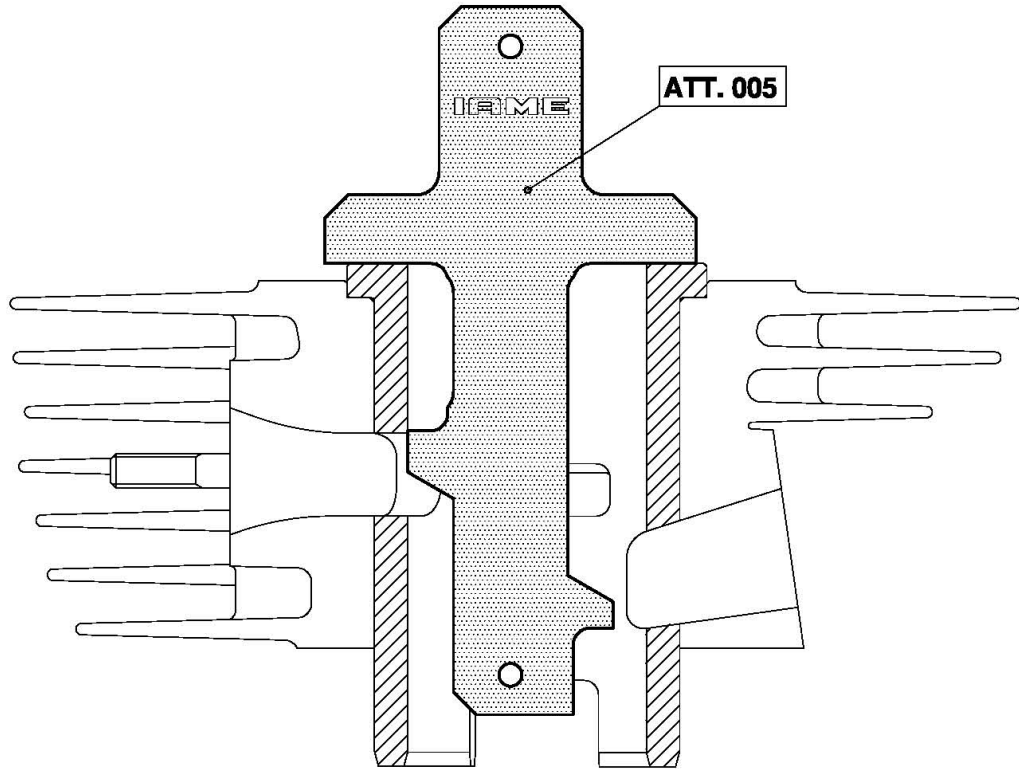

**CHECK THAT THE TOOL DOES NOT ENTER INTO THE EXHAUST AND INLET PORTS**

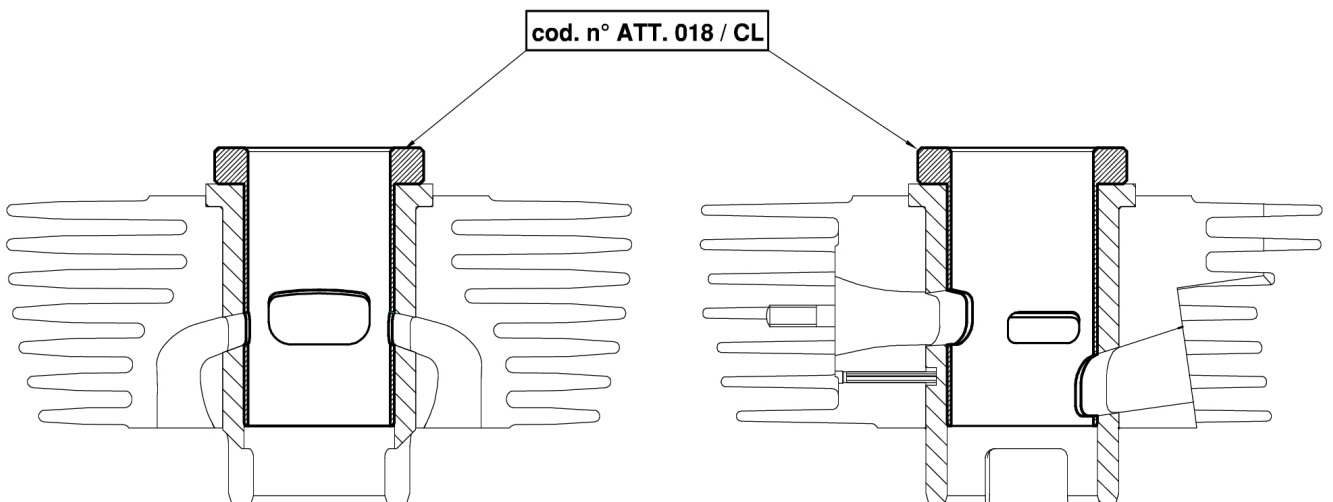

**VISUAL CHECK OF PORTS**

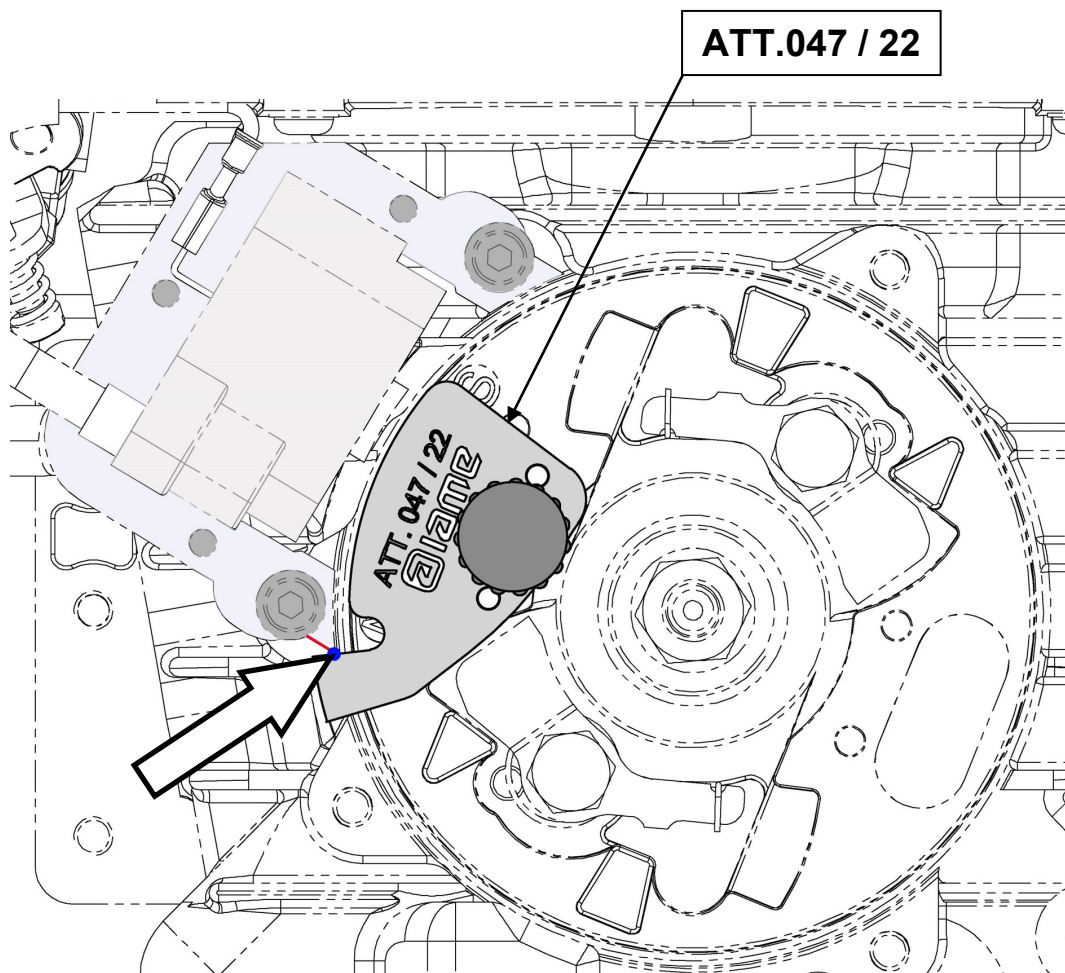
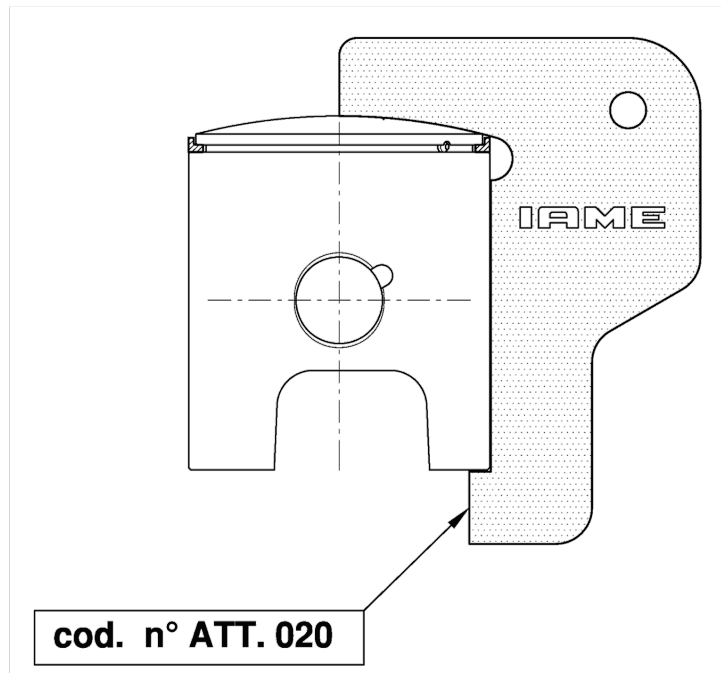

**CHECK THE CORRECT ALIGNMENT OF THE IGNITION ROTOR**



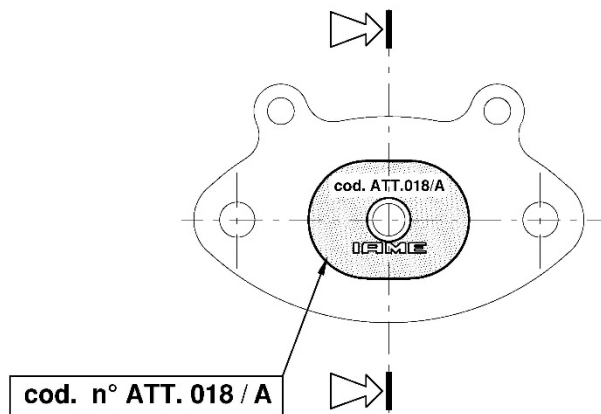
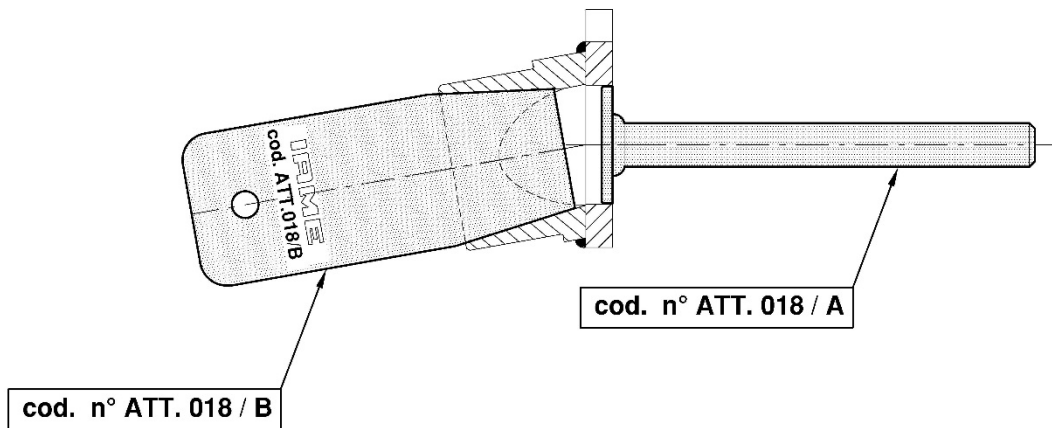

**CHECK THAT THE TOOL MUST BE THE SAME SHAPE OF THE EXHAUST  
MANIFOLD.  
(MINI CLASS)**

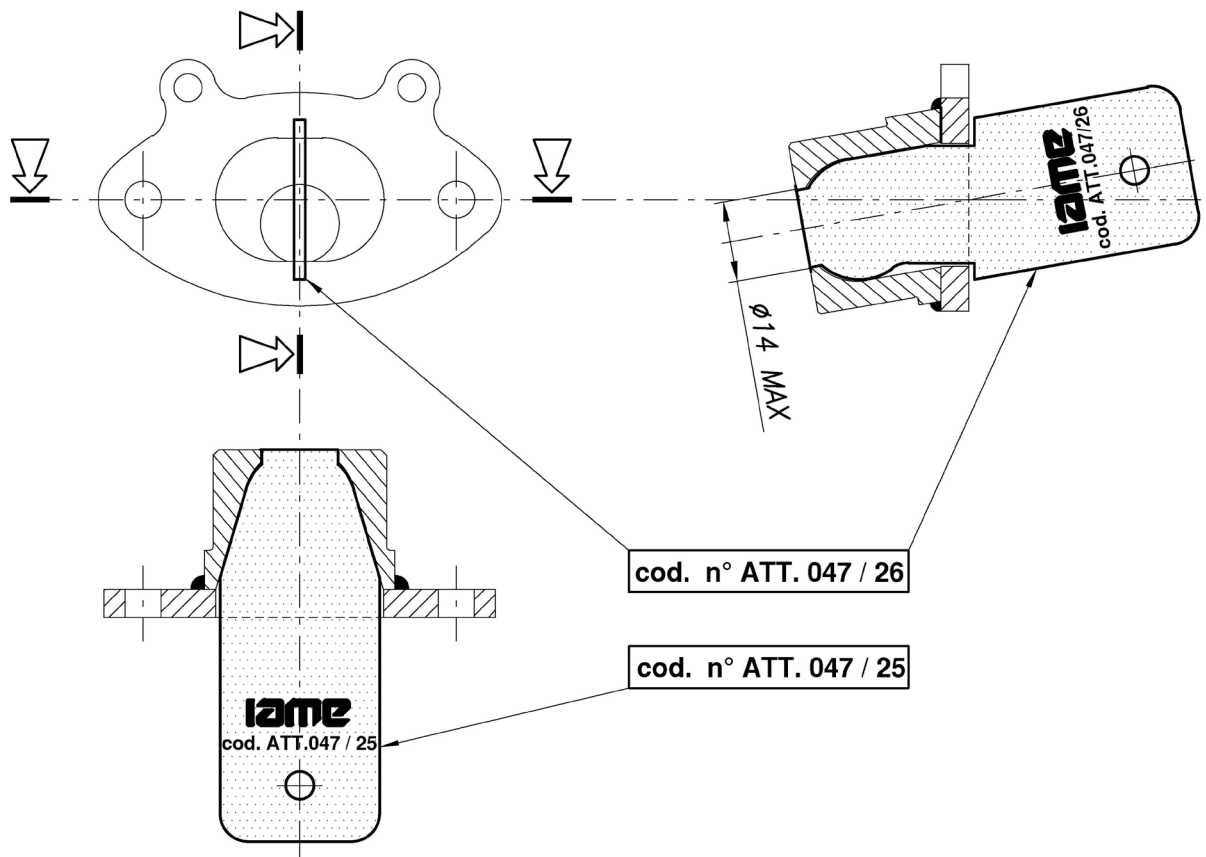

**CHECK THAT THE TOOL MUST BE THE SAME SHAPE OF THE EXHAUST  
RESTRICTOR  $\varnothing 14$  MAX.  
(CADETTI CLASS)**

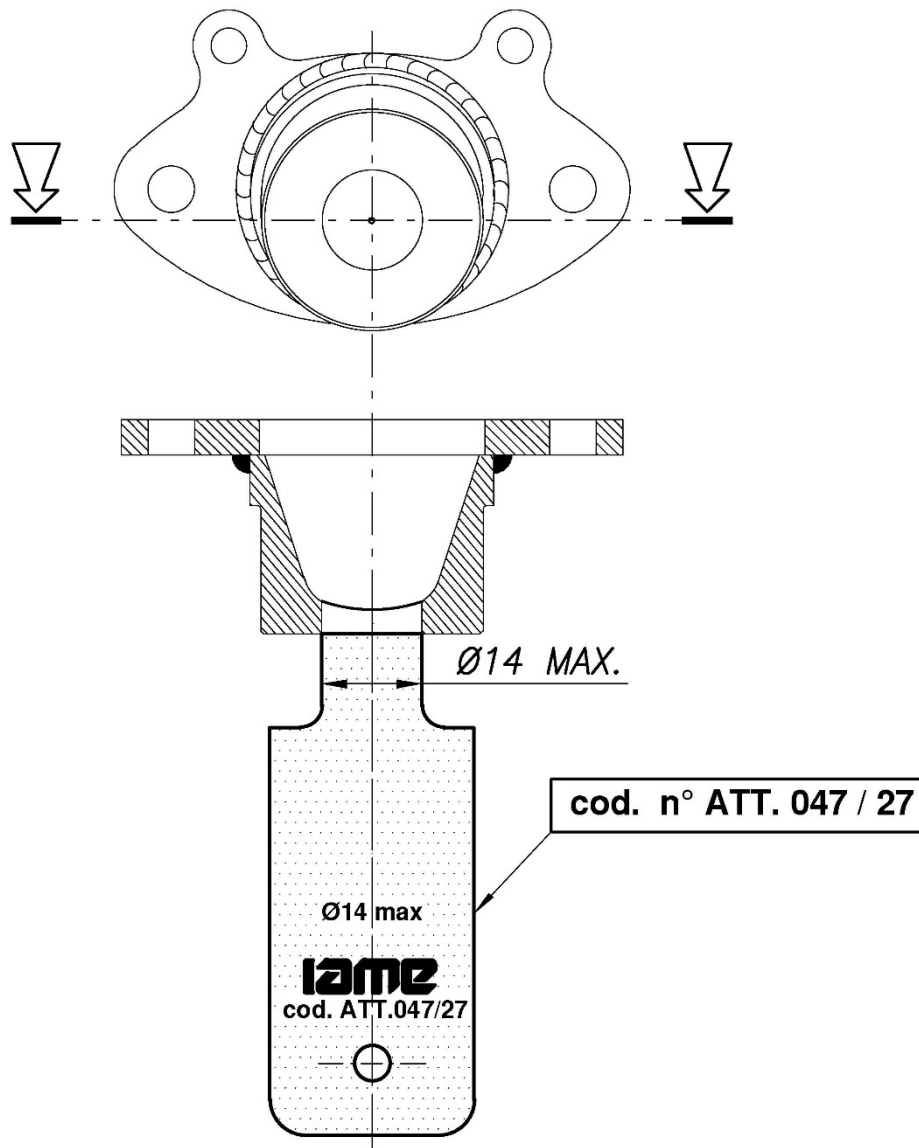

**CHECK THAT THE TOOL DOES NOT ENTER INTO THE EXHAUST  
RESTRICTOR.  
(CADETTI CLASS)**

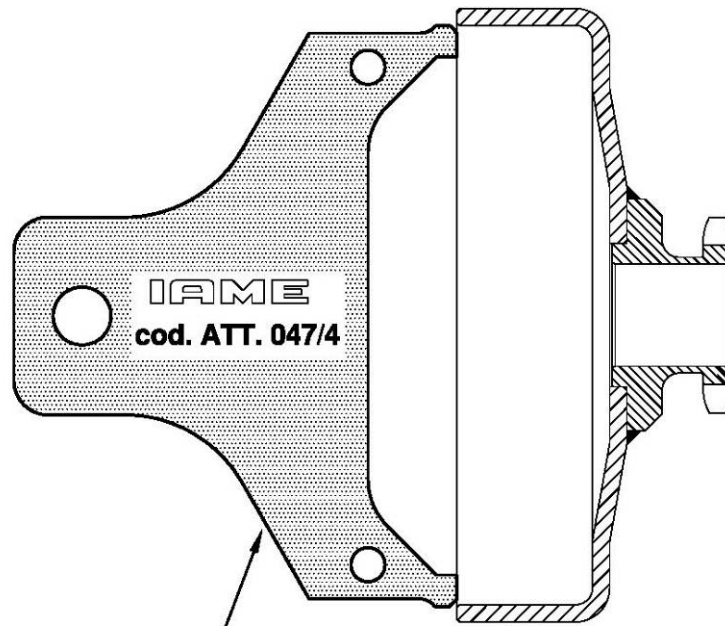

cod. n° ATT. 047 / 4

**CHECK THAT THE TOOL DOES NOT ENTER INTO THE CLUTCH DRUM IN PERPENDICULAR POSITION RESPECT AT THE CLUTCH DRUM AXIS.**

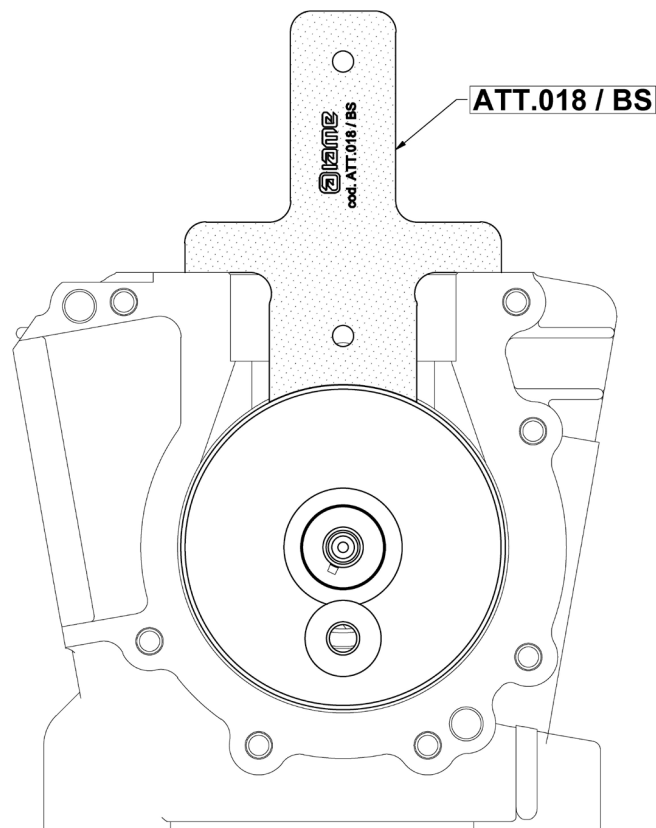

**VISUAL CHECKING OF CRANKCASE PLANE HEIGHT**

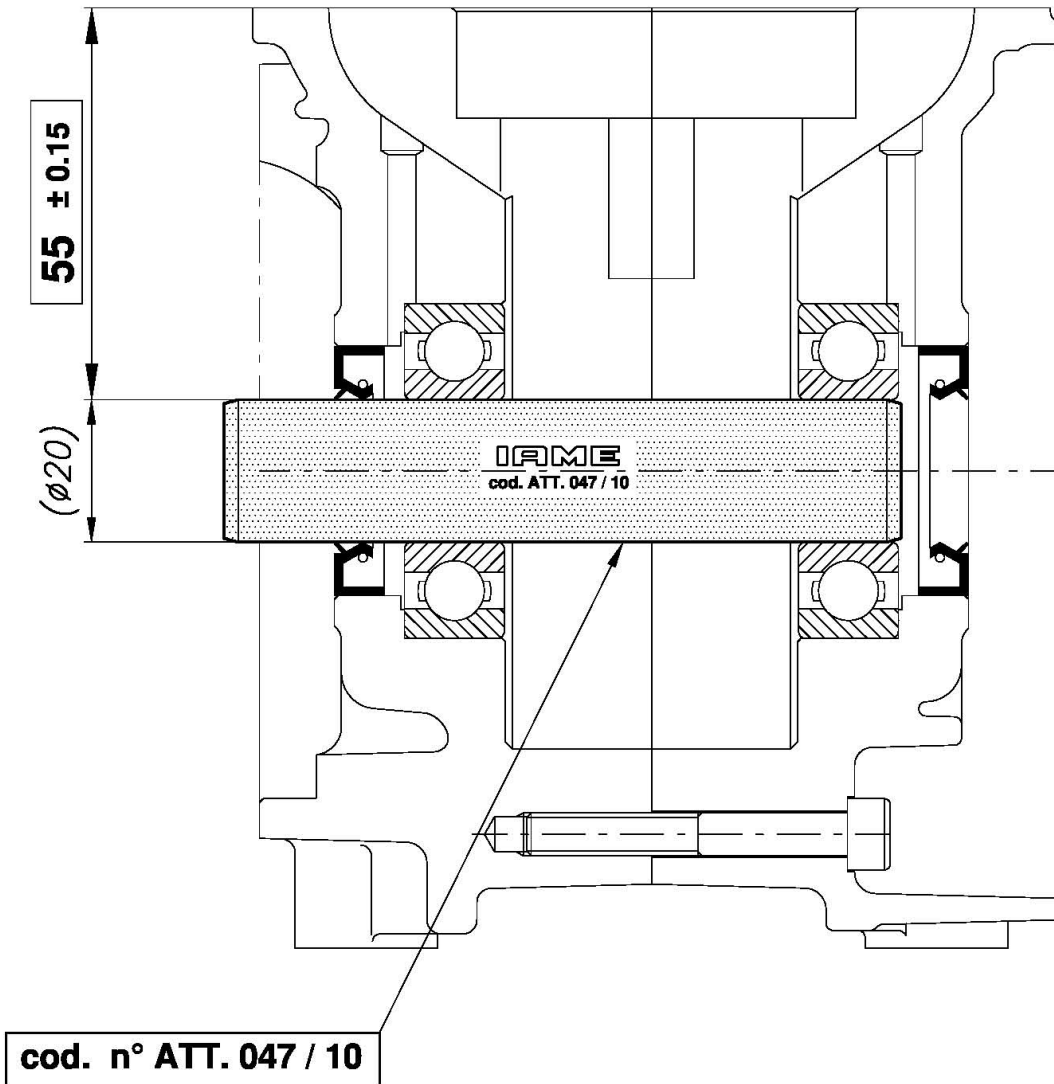

## CHECKING DIMENSIONS OF CRANKCASE PLANE HEIGHT

# CHECKING TOOLS FOR CARBURETTOR TILLOTSON HW-47A

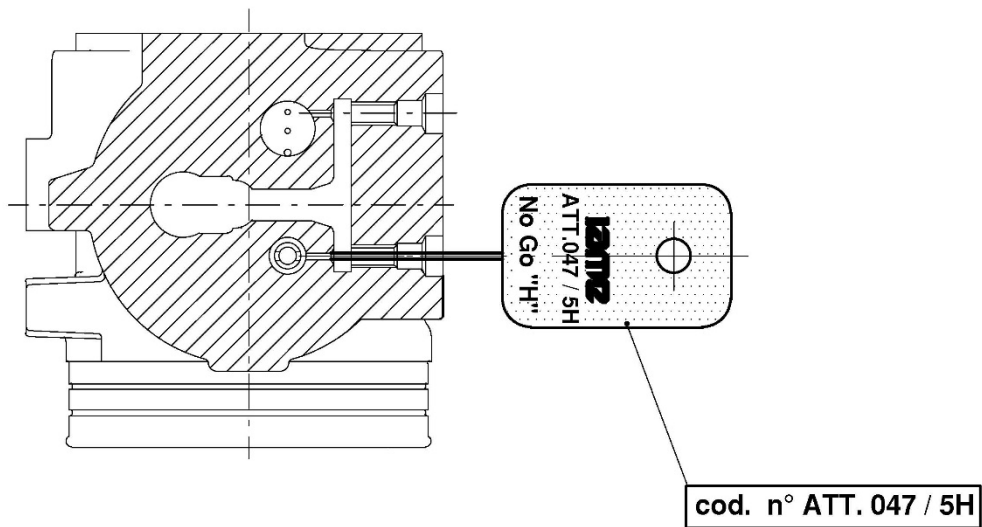
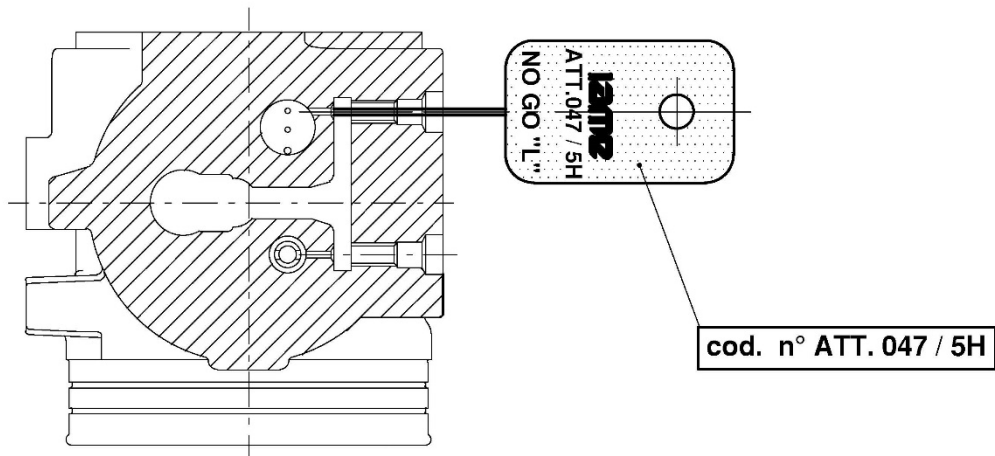

**CHECK THAT THE SPIKES DOES NOT ENTER INTO THE HOLES.**

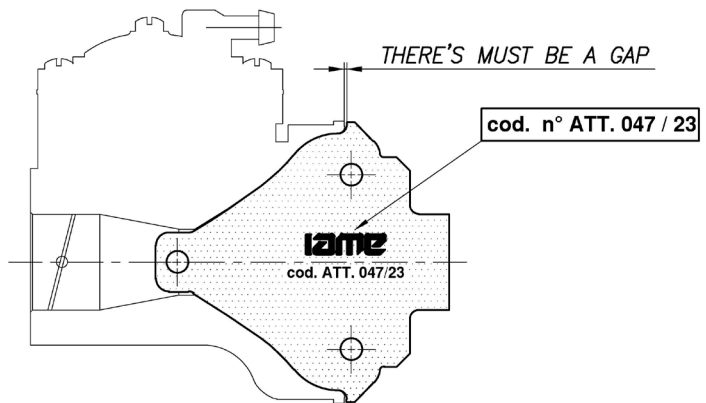

**CHECK THAT THE TOOL MUST BE THE SAME SHAPE OF THE INLET CARBURETTOR.**

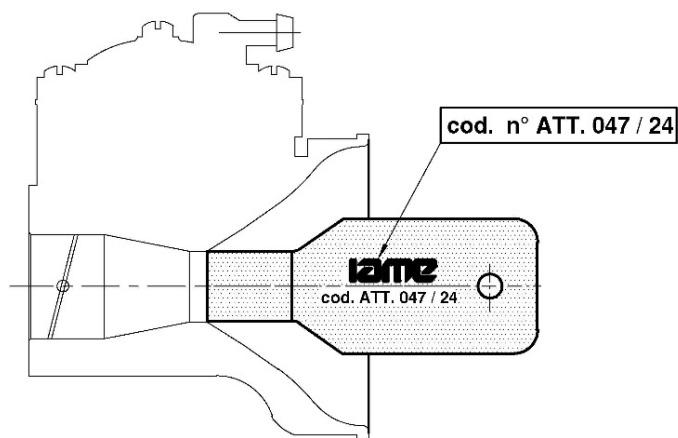

**CHECK THAT THE TOOL DOES NOT ENTER INTO THE VENTURE DUCT INLET OF CARBURETTOR.**

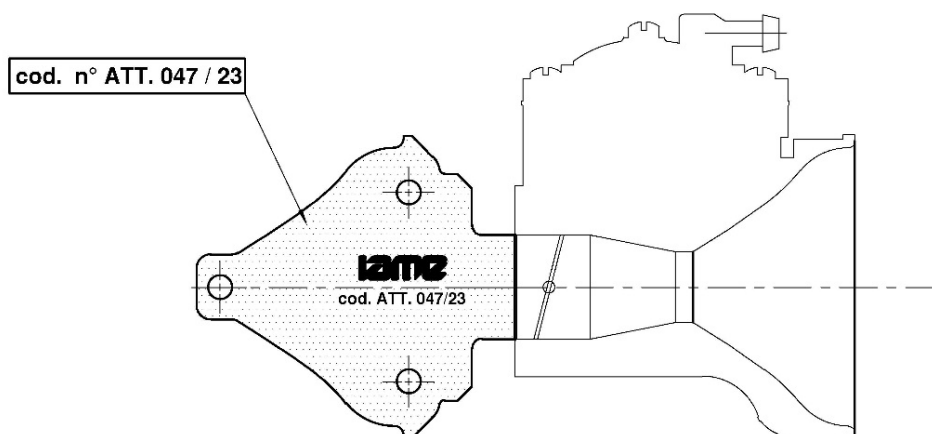

**CHECK THAT THE TOOL DOES NOT ENTER INTO THE VENTURE DUCT INLET OF CARBURETTOR.**

## CHECKING TOOLS FOR CARBURETTOR TILLOTSON HW-34B

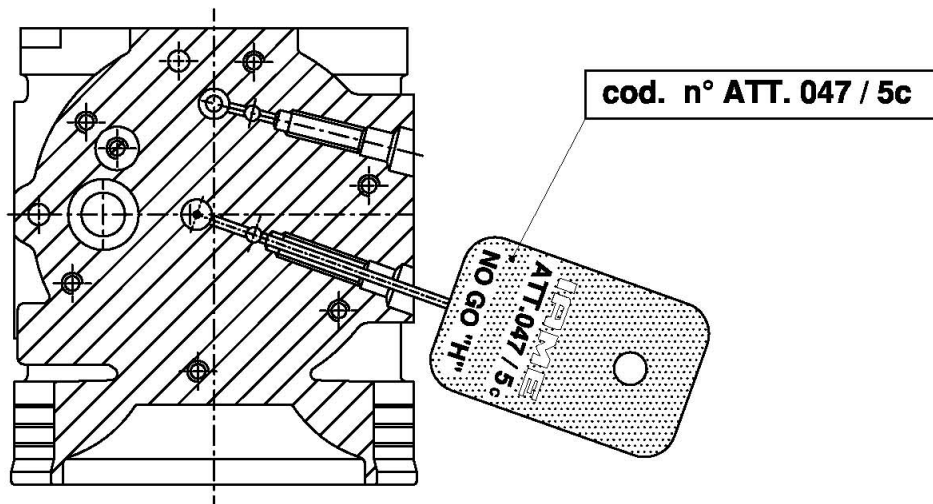
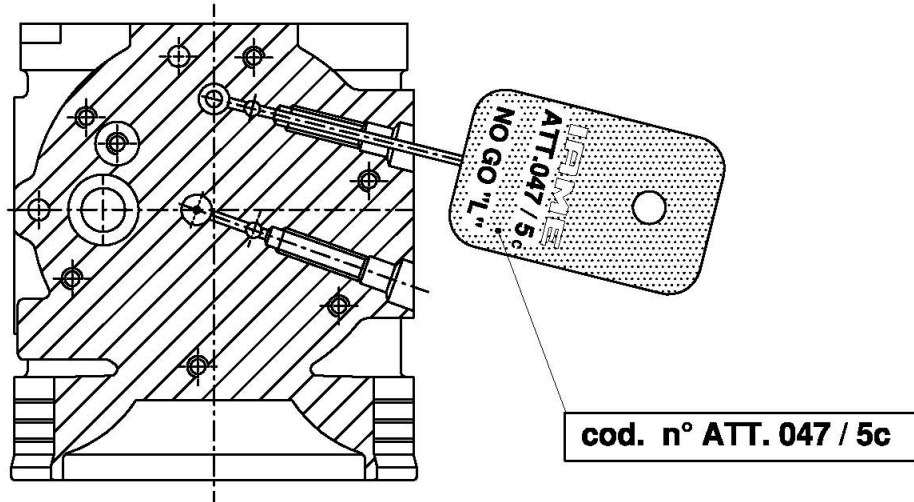

**CHECK THAT THE SPIKES DOES NOT ENTER INTO THE HOLES.**



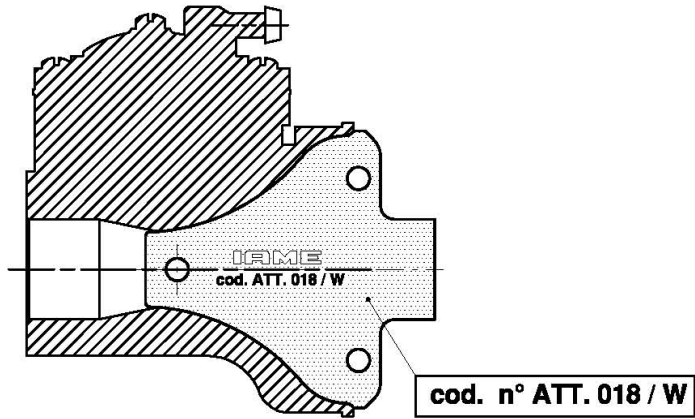

**CHECK THAT THE TOOL MUST BE THE SAME SHAPE OF THE INLET CARBURETTOR.**

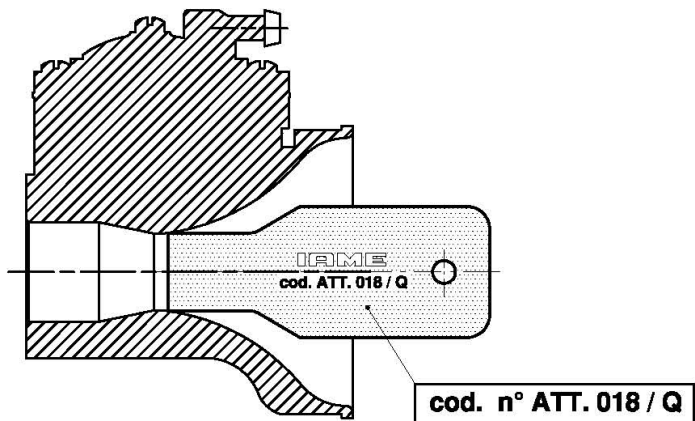

**CHECK THAT THE TOOL DOES NOT ENTER INTO THE VENTURE DUCT INLET OF CARBURETTOR.**

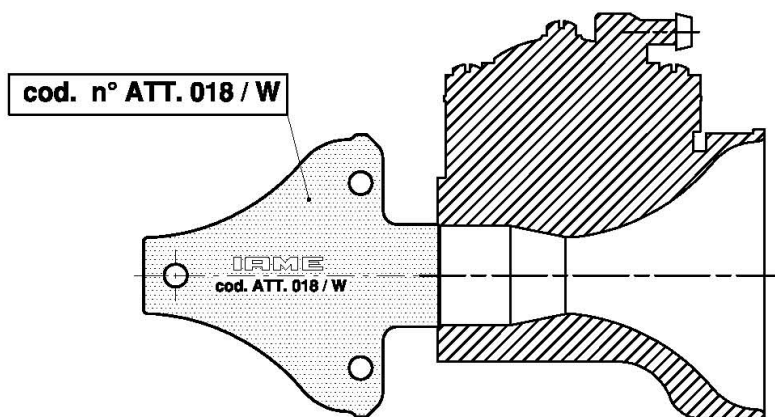

**CHECK THAT THE TOOL DOES NOT ENTER INTO THE VENTURE DUCT OUTLET OF CARBURETTOR.**

## IGNITION BENCH TESTER

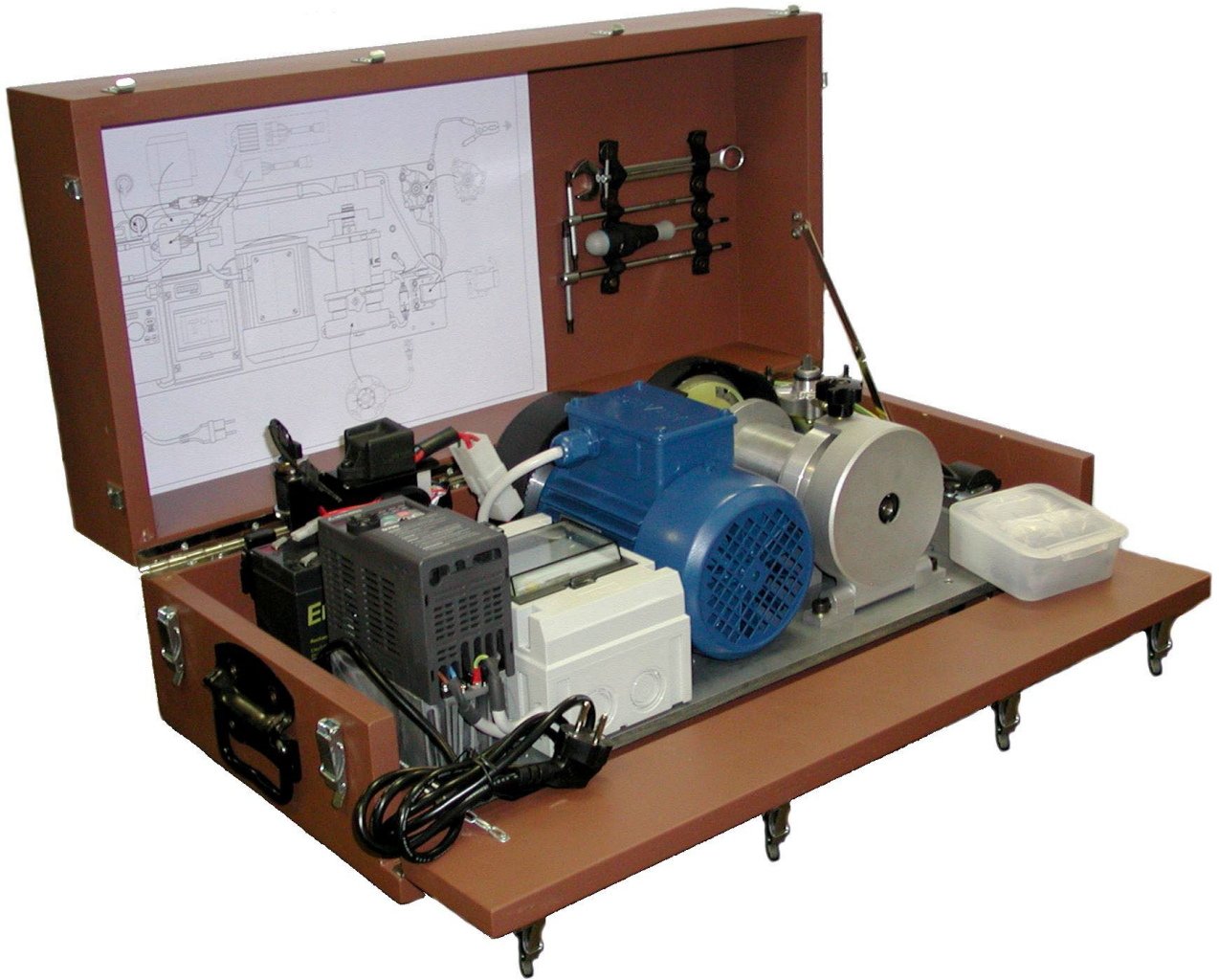



**CARBURETTOR**  
**Tillotson HW-47A**

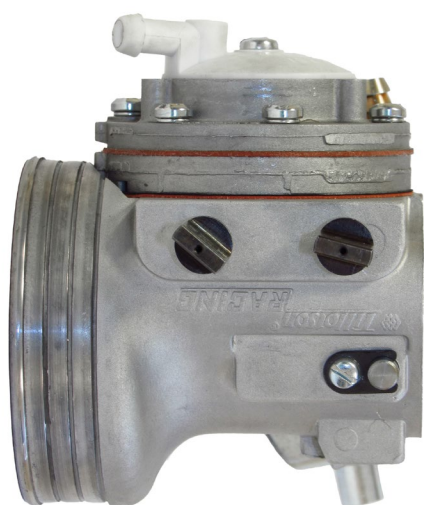

PHOTO OF ADJUSTING SIDE



PHOTO OF INLET SIDE

Manufacturer	<b>TILLOTSON LTD.</b>
Make	<b>TILLOTSON</b>
Model	<b>HW-47A</b>

## SECTION VIEW

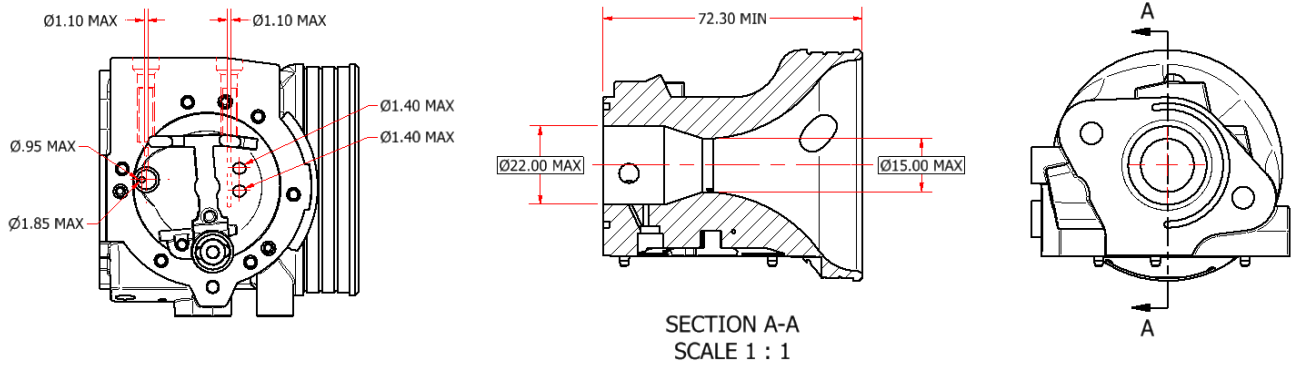

## MARKING

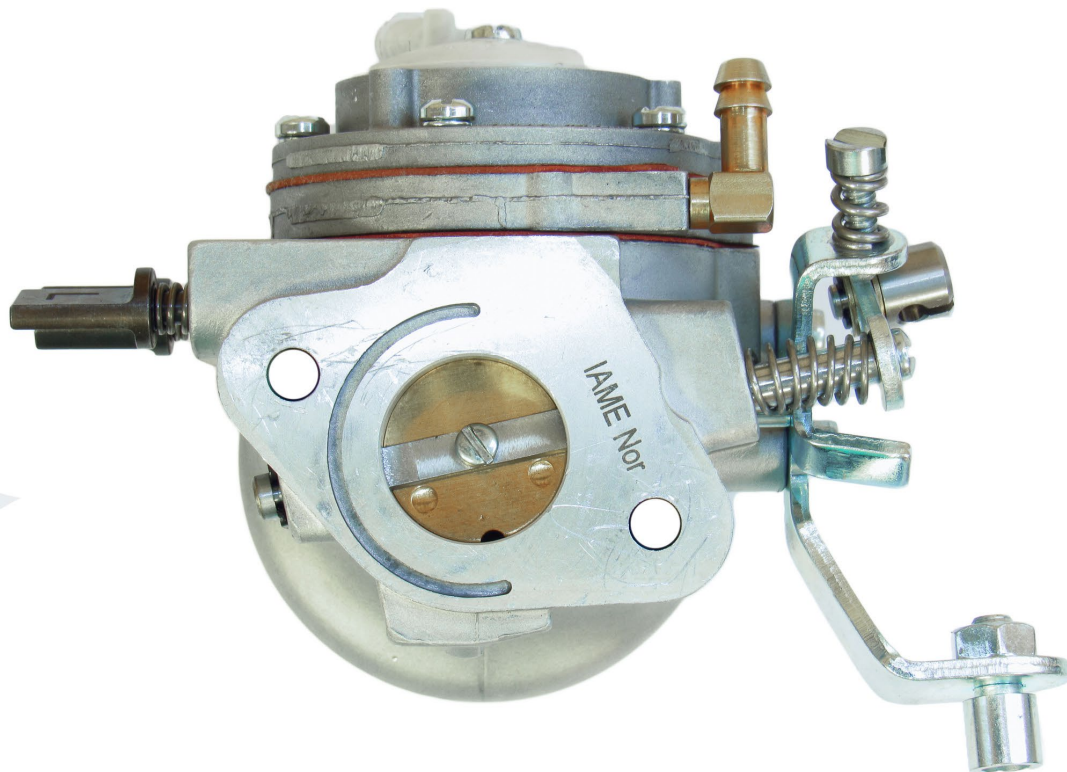

# CARBURETTOR DESCRIPTION AND SKETCH OF PARTS



**HW-47A EXPLODED VIEW**

DATE 05/02/2020	DRAWN BY P.B	REVISION 01
--------------------	-----------------	----------------

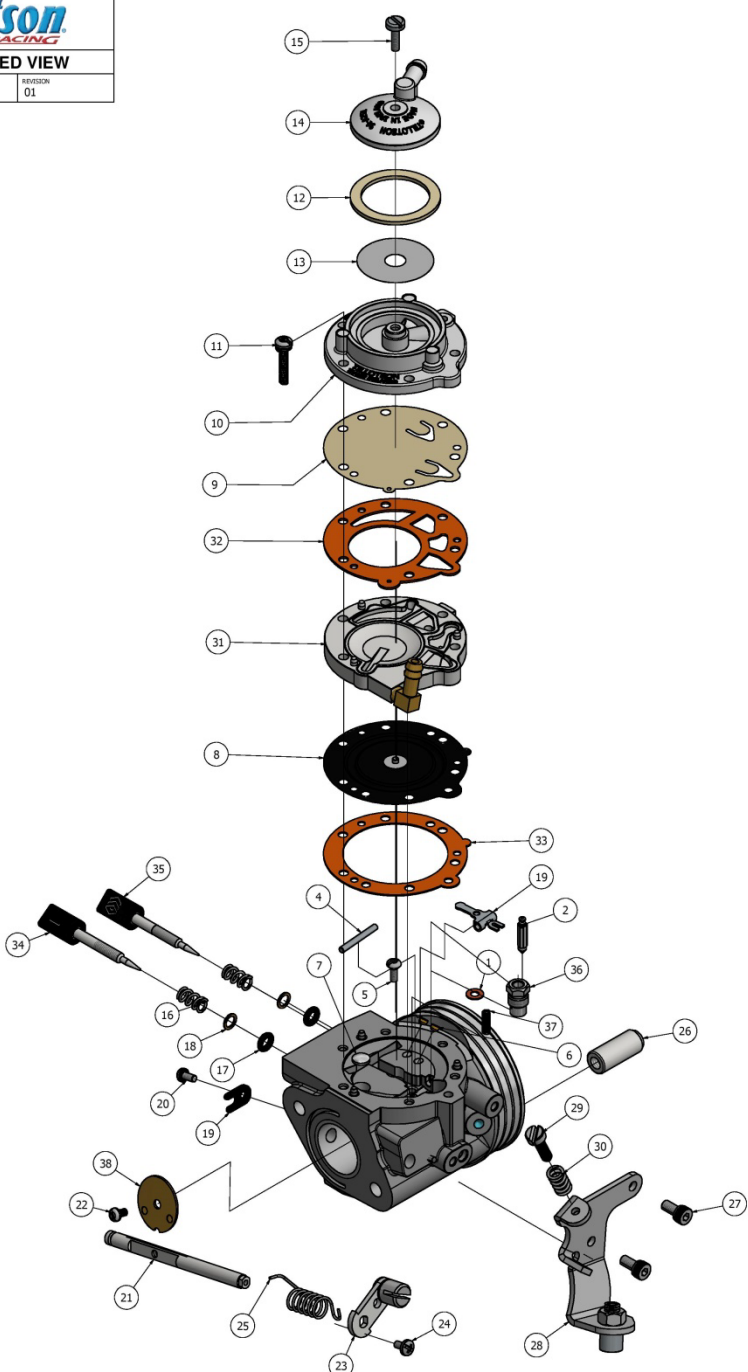

ITEM	QTY	PART NUMBER	DESCRIPTION	ITEM	QTY	PART NUMBER	DESCRIPTION	ITEM	QTY	PART NUMBER	DESCRIPTION
1	1	16-B199	+* INLET SEAT GASKET	16	2	24-B449	ADJUSTMENT SCREW SPRING	31	1	91-1031	METERING COVER ASSEMBLY
2	1	34-215	+ INLET NEEDLE	17	2	44-361	ADJUSTMENT SCREW O-RING	32	1	16-B407	+* FUEL PUMP GASKET (ORANGE)
3	1	155-A27	+ INLET CONTROL LEVER	18	2	78A-256	ADJUSTMENT SCREW WASHER	33	1	16-B406	+* DIAPHRAGM GASKET (ORANGE)
4	1	32-79	FULCRUM LEVER PIN	19	1	29-224	THROTTLE SHAFT CLIP	34	1	43-1046	8-32 UNC ADJUSTMENT SCREW L
5	1	15-B329	FULCRUM LEVER SCREW	20	1	15-C19	4-40 UNC SCREW	35	1	43-1045	M4 X 0.5 ADJUSTMENT SCREW H
6	2	80-160	BRASS PLUG	21	1	13-B215	THROTTLE SHAFT	36	1	36-A42	+ INLET SEAT
7	1	179-62	WELCH PLUG	22	1	15-C20	4-40 UNC SCREW	37	1	24-C297	INLET TENSION SPRING 46g
8	1	237-600	+* DIAPHRAGM ASSEMBLY	23	1	12-1218	THROTTLE LEVER ASSEMBLY	38	1	14-A137	THROTTLE SHUTTER
9	1	237-162	+* FUEL PUMP DIAPHRAGM	24	1	15-C52	4-40 UNC SCREW				
10	1	141-89	FUEL PUMP BODY	25	1	24-B381	THROTTLE RETURN SPRING			*	REPAIR KIT CONTENTS
11	6	15-C51	6- 32 UNC SCREW WITH L/W	26	2	81-377	CARBURETTOR MOUNTING NUT			+	DIAPHRAGM & GASKET KIT CONTENTS
12	1	16-B205	+* FUEL STRAINER COVER GASKET	27	2	15-C67	M4 X 0.7 SOCKET CAP SCREW				
13	1	95 - 170	FUEL STRAINER SCREEN	28	1	136-A51	CABLE BRACKET				
14	1	91-A251	FUEL STRAINER COVER	29	1	15-C9	LIMITER SCREW				
15	1	15-B313	5-40 UNC SCREW	30	1	24-B131	SPEED CREW SPRING				

PARTS OF CARBURETTOR

REF.33 - P. N°16-B406  
DIAPHRAGM GASKET (ORANGE COLOR)



Thickness =  $0.5 \pm 0.1$  mm

REF.32 - P. N° 16-B407  
PUMP DIAPHRAGM GASKET (ORANGE COLOR)



Thickness =  $0.8 \pm 0.1$  mm

REF.8 - P. N°237-600  
DIAPHRAGM



Thickness =  $0.13 \pm 0.07$  mm

REF.9 - P. N°237-162  
PUMP DIAPHRAGM



Thickness =  $0.10 \pm 0.063$  mm

REF.31 - P. N° 91-1031  
DIAPHRAGM COVER



Thickness =  $6.75 \pm 0.15$  mm

REF.10 - P. N° 141-89  
PUMP COVER



Thickness =  $12.5 \pm 0.15$  mm

REF.38 - P. N° 14-A137  
THROTTLE SHUTTER

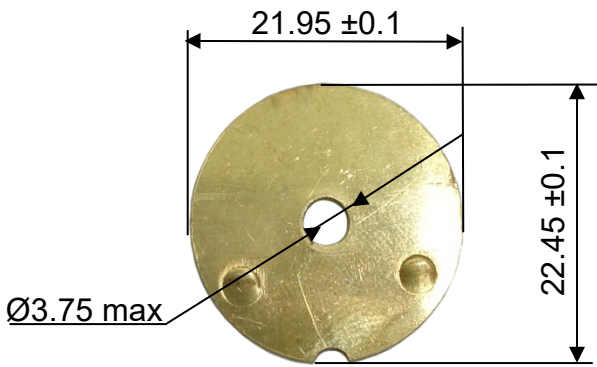

Thickness =  $0.81 \pm 0.1$  mm

REF.36 / 2 - P. N° 36-A42 / 34-216  
SEAT + NEEDLE

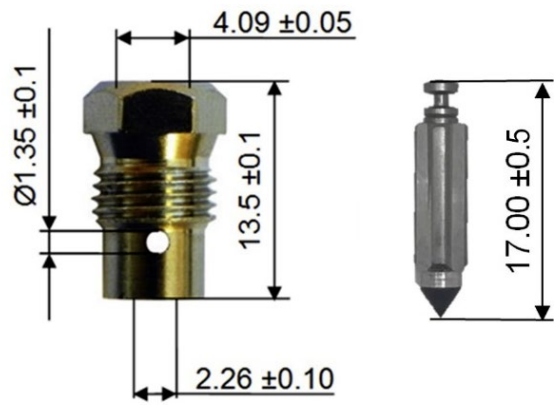

REF.34 - P. N° 43-1046  
NEEDLE LOW SPEED

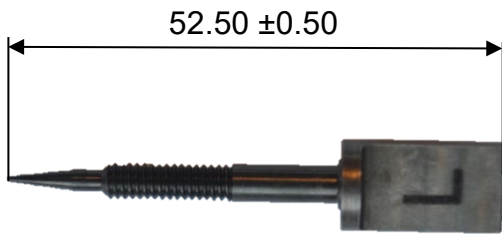

REF.35 - P. N° 43-1045  
NEEDLE HIGH SPEED



**THE CARBURETTOR CAN HAVE THIS HOLE FOR SEALING**

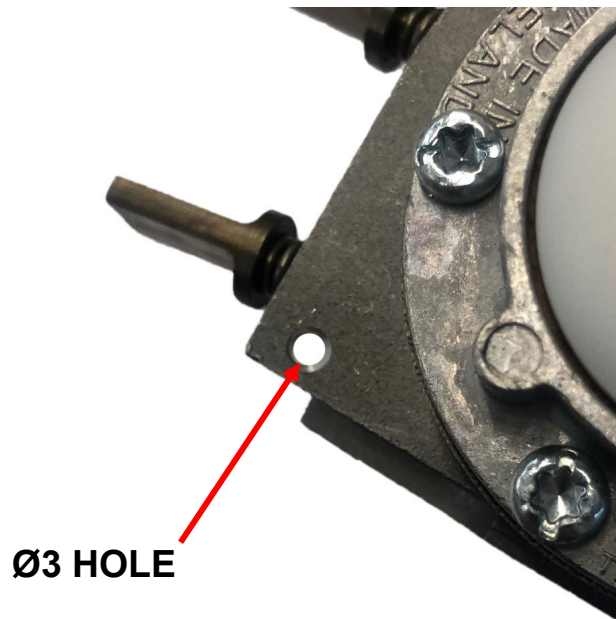

**CARBURETTOR**  
**Tillotson HW-34B**



PHOTO OF ADJUSTING SIDE

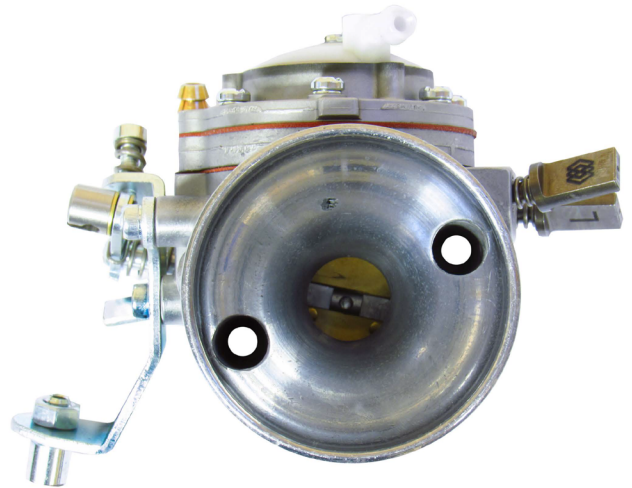
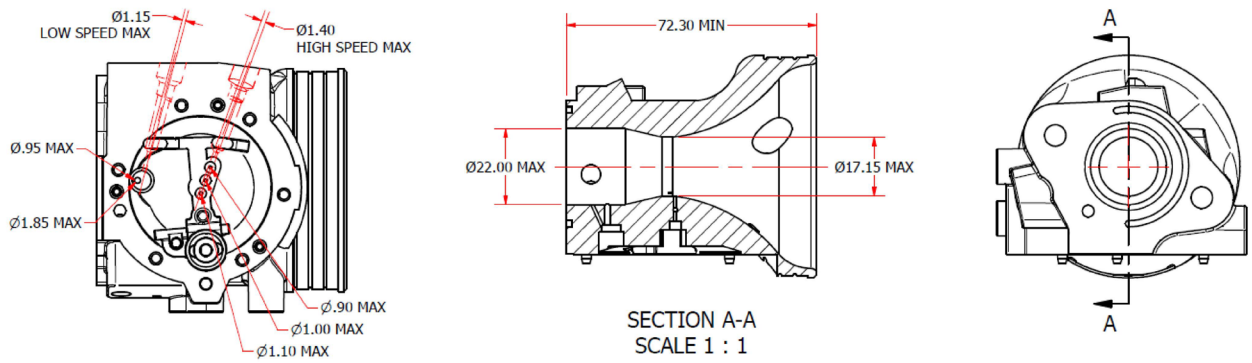

PHOTO OF INLET SIDE

Manufacturer	TILLOTSON LTD.
Make	TILLOTSON
Model	HW-34B



## SECTION VIEW



## MARKING

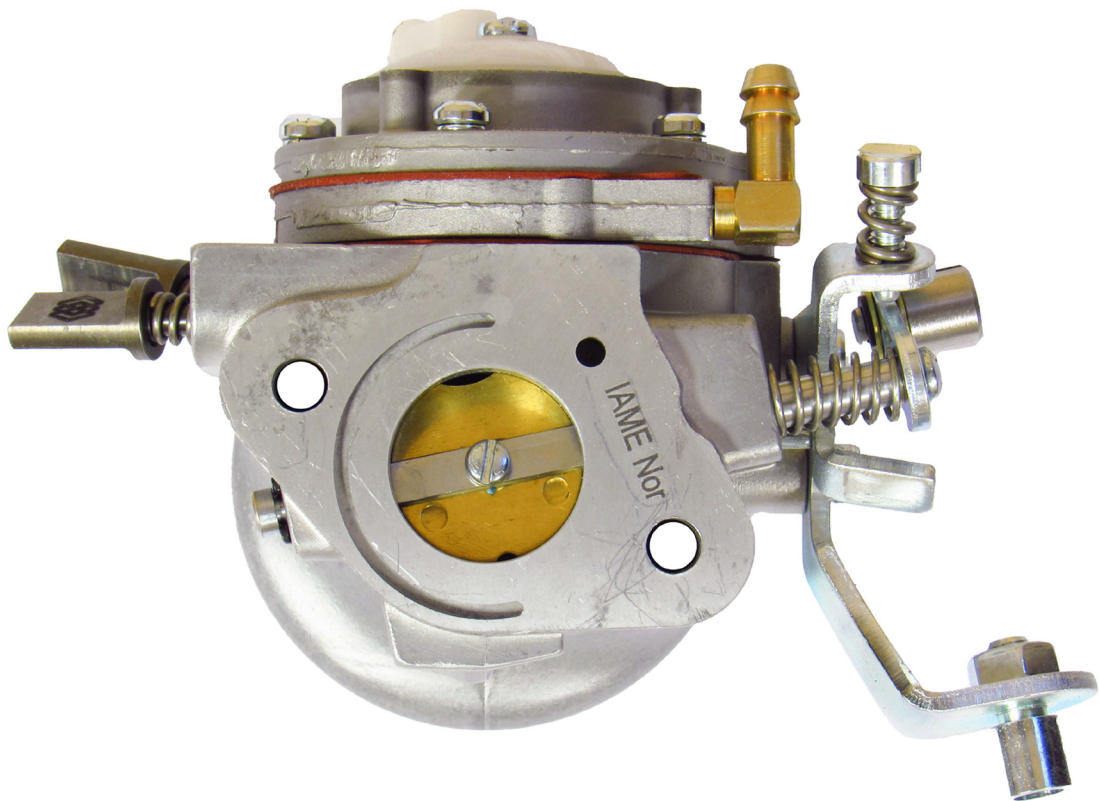

# CARBURETTOR DESCRIPTION AND SKETCH OF PARTS



## HW-34B EXPLODED VIEW

DATE 25/10/2019	DRAWN BY P.B	REVISION 00
--------------------	-----------------	----------------

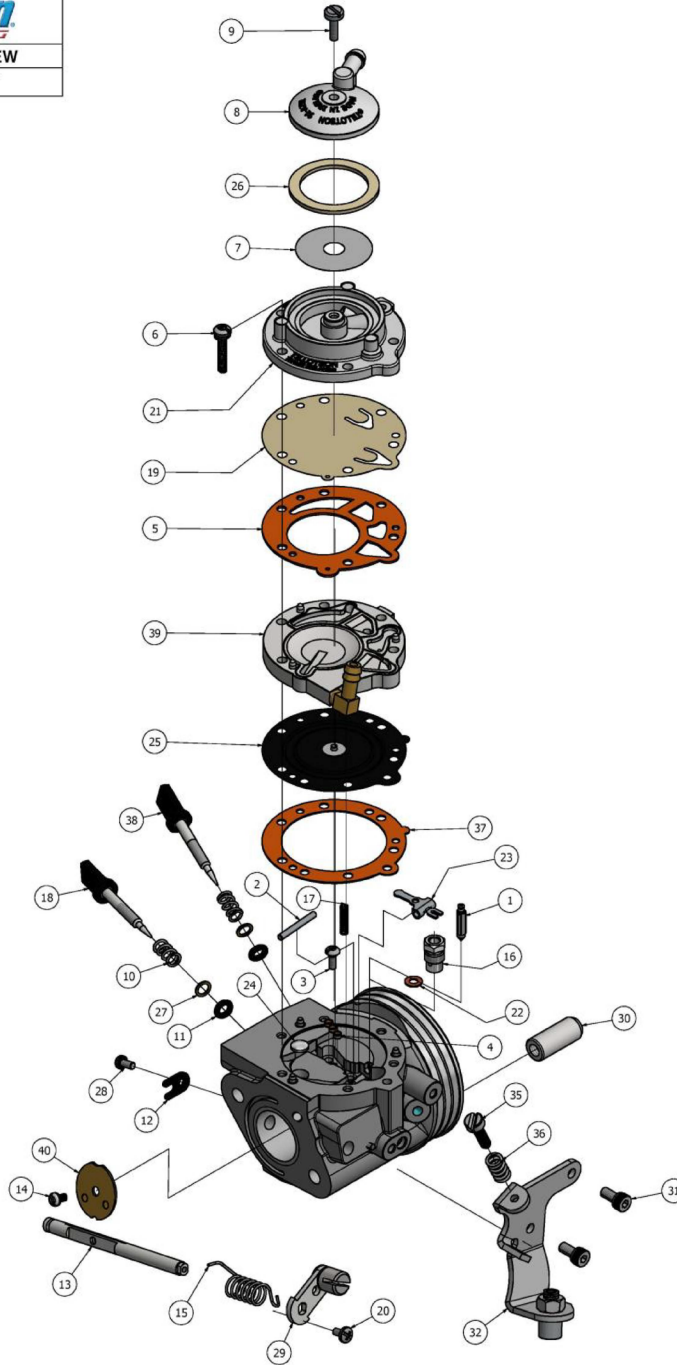

ITEM	QTY	PART NUMBER	DESCRIPTION	ITEM	QTY	PART NUMBER	DESCRIPTION	ITEM	QTY	PART NUMBER	DESCRIPTION
1	1	34-216	+ INLET NEEDLE	16	1	36-A42	+ INLET SEAT	31	2	15-C67	M4 X 0.7 SOCKET CAP SCREW
2	1	32-79	FULCRUM LEVER PIN	17	1	24-C298	INLET TENSION SPRING 42g	32	1	136-A51	CABLE BRACKET
3	1	15-B329	FULCRUM LEVER SCREW	18	1	43-1046	8-32 UNC ADJUSTMENT SCREW L	35	1	15-C9	LIMITER SCREW
4	3	80-160	BRASS PLUG	19	1	237-162	+* FUEL PUMP DIAPHRAGM	36	1	24-B131	SPEED CREW SPRING
5	1	16-B407	+* FUEL PUMP GASKET (ORANGE)	20	1	15-C52	4-40 UNC SCREW	37	1	16-B406	+* DIAPHRAGM GASKET (ORANGE)
6	6	15-C51	6 - 32 UNC SCREW WITH L/W	21	1	141-89	FUEL PUMP BODY	38	1	43-1045	M4 X 0.5 ADJUSTMENT SCREW H
7	1	95 - 170	FUEL STRAINER SCREEN	22	1	16-B199	+* INLET SEAT GASKET	39	1	91-1031	METERING COVER ASSEMBLY
8	1	91-A251	FUEL STRAINER COVER	23	1	155-A27	+ INLET CONTROL LEVER	40	1	14-A135	THROTTLE SHUTTER
9	1	15-B313	5-40 UNC SCREW	24	1	179-62	WELCH PLUG				
10	2	24-B449	ADJUSTMENT SCREW SPRING	25	1	237-600	+* DIAPHRAGM ASSEMBLY				
11	2	44-361	ADJUSTMENT SCREW O-RING	26	1	16-B205	+* FUEL STRAINER COVER GASKET			*	REPAIR KIT CONTENTS
12	1	29-224	THROTTLE SHAFT CLIP	27	2	78A-256	ADJUSTMENT SCREW WASHER			+	DIAPHRAGM & GASKET KIT CONTENTS
13	1	13-B215	THROTTLE SHAFT	28	1	15-C19	4-40 UNC SCREW				
14	1	15-C20	4-40 UNC SCREW	29	1	12-1218	THROTTLE LEVER ASSEMBLY			RK-6HW	REPAIR KIT
15	1	24-B381	THROTTLE RETURN SPRING	30	2	81-377	CARBURETTOR MOUNTING NUT			DG--3HW	DIAPHRAGM & GASKET KIT

PARTS OF CARBURETTOR

REF.37 - P. N°16-B406  
DIAPHRAGM GASKET (ORANGE COLOR)



Thickness =  $0.5 \pm 0.1$  mm

REF.5 - P. N° 16-B407  
PUMP DIAPHRAGM GASKET (ORANGE COLOR)

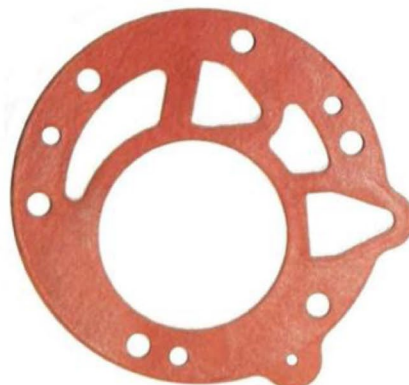

Thickness =  $0.8 \pm 0.1$  mm

REF.25 - P. N°237-600  
DIAPHRAGM



Thickness =  $0.13 \pm 0.07$  mm

REF.19 - P. N°237-162  
PUMP DIAPHRAGM



Thickness =  $0.10 \pm 0.063$  mm

REF.39 - P. N° 91-1031  
DIAPHRAGM COVER



Thickness =  $6.75 \pm 0.15$  mm

REF.21 - P. N° 141-89  
PUMP COVER



Thickness =  $12.5 \pm 0.15$  mm

REF.40 - P. N° 14-A135  
THROTTLE SHUTTER

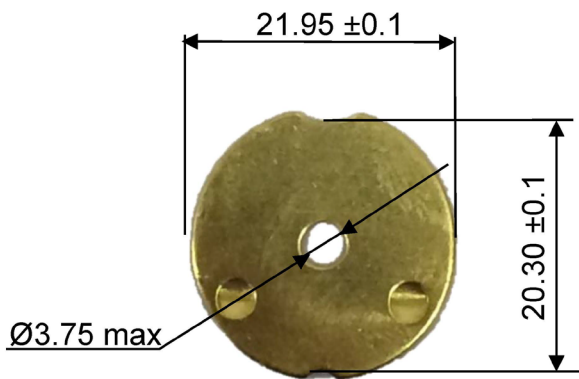

Thickness =  $0.81 \pm 0.1$  mm

REF.16 / 1 - P. N° 233-721P  
SEAT P.N° 34-A42 + NEEDLE P.N° 34-216

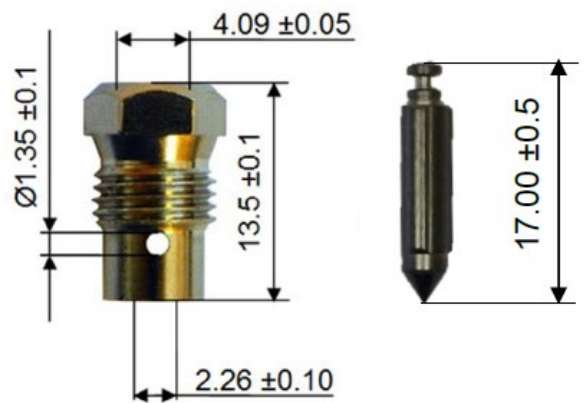

REF.18 - P. N° 43-1046  
NEEDLE LOW SPEED



REF.38 - P. N° 43-1045  
NEEDLE HIGH SPEED



**The carburettor can have this hole for sealing.**

